



Manual Reset Limit Switch

D4D-□□R

A Series of Pull-reset Models Available

- The Switches, which feature a direct opening mechanism (NC contacts only), are equipped with lockable heads. Lock the Switch by moving the actuator to the lock position, and release the lock using the reset button.
- Conforms to EN (TÜV) standards corresponding to the CE marking. (Direct opening mechanism is shown by  on the Switch.)
- Approved by UL, CSA, BIA, and SUVA standards.
- Direct opening mechanism  and double insulation  approved by TÜV and BIA.
- Operates between -30°C and 70°C.
- Metric conduit types available



Model Number Structure

■ Model Number Legend

D4D-□□□□R
1 2 3

1. Conduit

- 1: Pg13.5 (1-conduit)
- 2: G1/2 (1-conduit)
- 3: 1/2-14NPT (1-conduit)
- 4: M20
- 5: Pg13.5 (2-conduit)
- 6: G1/2 (2-conduit)
- 8: M20 (2-conduit)

2. Built-in Switch

- 5: 1NC/1NO (slow-action)
- 6: 1NC/1NO (slow-action) gold-plated contacts
- A: 2NC (slow-action)
- B: 2NC (slow-action) gold-plated contacts

3. Actuator









- 20: Roller lever
- 21: Adjustable roller lever
- 27: Adjustable roller lever (with rubber roller)
- 2H: Adjustable roller lever, form lock (with rubber roller)
- 31: Plunger
- 32: Roller plunger
- 62: One-way roller arm lever (Horizontal)
- 72: One-way roller arm lever (Vertical)

Ordering Information

List of Models

■ Safety limit switch, mechanical form lock

Switches

Actuator	Conduit size (see note 1)		1NC/1NO (Slow-action)		2NC (Slow-action)	
			Direct opening (see note 2)	Model	Direct opening (see note 2)	Model
Roller lever 	1-conduit	Pg13.5	⊕	D4D-1520R	⊕	D4D-1A20R
		G1/2		D4D-2520R		D4D-2A20R
		M20		D4D-4520R		
	2-conduit	Pg13.5		D4D-5520R		D4D-5A20R
		G1/2		D4D-6520R		D4D-6A20R
Plunger 	1-conduit	Pg13.5	⊕	D4D-1531R	⊕	D4D-1A31R
		G1/2		D4D-2531R		D4D-2A31R
		M20		D4D-4531R		
	2-conduit	Pg13.5		D4D-5531R		D4D-5A31R
		G1/2		D4D-6531R		D4D-6A31R
Roller plunger 	1-conduit	Pg13.5	⊕	D4D-1532R	⊕	D4D-1A32R
		G1/2		D4D-2532R		D4D-2A32R
		M20		D4D-4532R		
	2-conduit	Pg13.5		D4D-5532R		D4D-5A32R
		G1/2		D4D-6532R		D4D-6A32R
One-way roller arm lever (Horizontal) 	1-conduit	Pg13.5	⊕	D4D-1562R	⊕	D4D-1A62R
		G1/2		D4D-2562R		D4D-2A62R
	2-conduit	Pg13.5		D4D-5562R		D4D-5A62R
		G1/2		D4D-6562R		D4D-6A62R
One-way roller arm lever (Vertical) 	1-conduit	Pg13.5	⊕	D4D-1572R	⊕	D4D-1A72R
		G1/2		D4D-2572R		D4D-2A72R
	2-conduit	Pg13.5		D4D-5572R		D4D-5A72R
		G1/2		D4D-6572R		D4D-6A72R
Adjustable roller lever, form lock 	1-conduit	Pg13.5	⊕	D4D-152HR	⊕	D4D-1A2HR
		G1/2		D4D-252HR		D4D-2A2HR
Adjustable roller lever (See note 3) 	1-conduit	Pg13.5	---	D4D-1521R	---	D4D-1A21R
		G1/2		D4D-2521R		D4D-2A21R
		M20		D4D-4521R		
	2-conduit	Pg13.5		D4D-5521R		D4D-5A21R
		G1/2		D4D-6521R		D4D-6A21R
Adjustable roller lever (with rubber roller) (See note 3) 	1-conduit	Pg13.5	---	D4D-1527R	---	D4D-1A27R
		G1/2		D4D-2527R		D4D-2A27R
		M20		D4D-4527R		
	2-conduit	Pg13.5		D4D-5527R		D4D-5A27R
		G1/2		D4D-6527R		D4D-6A27R

- Note:** 1. It is recommended that M20/PG13.5 be used for Switches for Europe and 1/2-14NPT for North America.
 2. The Switches are marked with ⊕ indicating approval for the direct opening mechanism.
 3. Mechanically speaking, these models are basic limit switches.

Specifications

Approved Standards

Slow-action Models

Agency	Standard	File No.
TÜV Rheinland	EN60947-5-1 EN81, EN115	R9451184  (Direct opening: approved)
UL (see note 1)	UL508 CSA C22.2 No.14	E76675
BIA (see note 2)	GS-ET-15	1-conduit: 9505895 2-conduit: 9509914
SUVA (see note 2)	SUVA	1-conduit: E6337.d 2-conduit: E6338.d

Note: 1. CSA C22.2 No. 14 compliance was verified and approved by UL (Marked with ).

2. Except for adjustable roller lever models.

Standards and EC Directives

- Conforms to the following EC Directives:
 - Machinery Directive
 - Low Voltage Directive
 - EN50047
 - EN1088

Approved Standard Ratings

Applicable Standards

TÜV (EN60947-5-1)

Utilization category	AC-15
Rated operating current (I_e)	2 A
Rated operating voltage (U_e)	400 V

A600

UL (UL508/CSA C22.2 No.14)

Rated voltage	Carry current	Current		Volt-amperes	
		Make	Break	Make	Break
120 VAC	10 A	60 A	6 A	7,200 VA	720 VA
240 VAC		30 A	3 A		
480 VAC		15 A	1.5 A		
600 VAC		12 A	1.2 A		

Characteristics

Degree of protection	IP65 (EN60947-5-1)
Durability (see note)	Mechanical:1,000,000 operations min. Electrical:150,000 operations min.
Operating speed	1 mm/s to 0.5 m/s
Contact gap	2 x 2 mm min.
Operating frequency	30 operations/min
Rated frequency	50/60 Hz
Insulation resistance	100 MΩ min. (at 500 VDC) between terminals of the same polarity, and between each terminal and non-current-carrying metal part
Contact resistance	25 mΩ max. (initial value)
Dielectric strength (U _{imp})	U _{imp} 4 kV between terminals of the same polarity, between terminals of different polarity, and between each terminal and non-current-carrying metal part (EN60947-5-1)
Rated insulation voltage (U _i)	400 V (EN60947-5-1)
Switching overvoltage	1,500 V max. (EN60947-5-1)
Pollution degree (operating environment)	3 (EN60947-5-1)
Conditional short-circuit current	100 A (EN60947-5-1)
Conventional enclosed thermal current (I _{the})	10 A (EN60947-5-1)
Protection against electric shock	Class II (double insulation)
Vibration resistance	Malfunction:10 to 55 Hz, 0.75-mm single amplitude
Shock resistance	Destruction:1,000 m/s ² min. Malfunction:300 m/s ² min.
Ambient temperature	Operating:-30°C to 70°C (with no icing)
Ambient humidity	Operating:95% max.
Weight	Approx. 80 g (for D4D-1120R)

Note: The durability is for an ambient temperature of 5°C to 35°C and an ambient humidity of 40% to 70%. Contact your OMRON sales representative for more detailed information on other operating environments.

Operating Characteristics

1-conduit Models

Model	D4D-1520R D4D-2520R D4D-4520R D4D-1A20R D4D-2A20R	D4D-1521R D4D-2521R D4D-4521R D4D-1A21R D4D-2A21R (see note 1)	D4D-152HR D4D-252HR D4D-1A2HR D4D-2A2HR	D4D-1527R D4D-2527R D4D-4527R D4D-1A27R D4D-2A27R (see note 2)	D4D-1531R D4D-2531R D4D-4531R D4D-1A31R D4D-2A31R	D4D-1532R D4D-2532R D4D-4532R D4D-1A32R D4D-2A32R	D4D-1562R D4D-2562R D4D-1A62R D4D-2A62R	D4D-1572R D4D-2572R D4D-1A72R D4D-2A72R
LF max.	6.37 N	5.59 N	5.39 N	5.39 N	10.79 N	10.79 N	7.35 N	7.85 N
LT max.	55°	55°	55°	55°	4.5 mm	4.5 mm	7 mm	7 mm
PT1 max. (see note 3)	18° to 27°	18° to 27°	18° to 27°	18° to 27°	2 mm	2 mm	4 mm	4 mm
PT2 (see note 4)	(44°)	(44°)	(44°)	(44°)	(2.9 mm)	(2.9 mm)	(5.2 mm)	(4.3 mm)
OP	---	---	---	---	34±0.5 mm	44.4±0.8 mm	53±0.8 mm	27±0.8 mm
TT (see note 5)	(70°)	(70°)	(70°)	(70°)	(6 mm)	(6 mm)	(9 mm)	(9 mm)
DOF min. (see note 6)	19.61 N	19.61 N	19.61 N	19.61 N	19.61 N	19.61 N	19.61 N	19.61 N
DOT min. (see note 6)	50°	50°	50°	50°	3.2 mm	3.2 mm	5.8 mm	4.8 mm

- Note:**
- The operating characteristics of these Switches were measured with the roller lever set at 30 mm.
 - The operating characteristics of these Switches were measured with the roller lever set at 31 mm.
 - These PT1 values are possible when the NC contacts are OFF.
 - These PT2 values are possible when the NO contacts are ON (applicable to D4D-□R models with 1NC and 1NO contact each).
 - Reference value.
 - DOT (direct opening travel) and DOF (direct opening force) are required values for direct opening.

2-conduit Models

Model	D4D-5520R D4D-6520R D4D-5A20R D4D-6A20R	D4D-5521R D4D-6521R D4D-5A21R D4D-6A21R	D4D-5527R D4D-6527R D4D-5A27R D4D-6A27R	D4D-5531R D4D-6531R D4D-5A31R D4D-6A31R	D4D-5532R D4D-6532R D4D-5A32R D4D-6A32R	D4D-5562R D4D-6562R D4D-5A62R D4D-6A62R	D4D-5572R D4D-6572R D4D-5A72R D4D-6A72R
LF max.	6.37 N	5.59 N	5.39 N	10.79 N	10.79 N	7.35 N	7.85 N
LT max.	55°	55°	55°	4.5 mm	4.5 mm	7 mm	7 mm
PT1 max. (see note 3)	18° to 27°	18° to 27°	18° to 27°	2 mm	2 mm	4 mm	4 mm
PT2 (see note 4)	(44°)	(44°)	(44°)	(2.9 mm)	(2.9 mm)	(5.2 mm)	(4.3 mm)
OP	---	---	---	34±0.5 mm	44.4±0.8 mm	53±0.8 mm	27±0.8 mm
TT (see note 5)	(70°)	(70°)	(70°)	(6 mm)	(6 mm)	(9 mm)	(9 mm)
DOF min. (see note 6)	19.61 N	19.61 N	19.61 N	19.61 N	19.61 N	19.61 N	19.61 N
DOT min. (see note 6)	50°	50°	50°	3.2 mm	3.2 mm	5.8 mm	4.8 mm

- Note:**
1. The operating characteristics of these Switches were measured with the roller lever set at 30 mm.
 2. The operating characteristics of these Switches were measured with the roller lever set at 31 mm.
 3. These PT1 values are possible when the NC contacts are OFF.
 4. These PT2 values are possible when the NO contacts are ON (applicable to D4D-□R models with 1NC and 1NO contact each).
 5. Reference value.
 6. DOT (direct opening travel) and DOF (direct opening force) are required values for direct opening.

Contact Form

Model	Contact	Diagram	Remarks
D4D-□5□N	1NC/1NO (slow-action)		<p>11-12 23-24</p> <p>Stroke →</p> <p>ON</p> <p>Only NC contact 11-12 has an approved direct opening mechanism. →</p> <p>Terminals 11-12 and 23-24 can be used as unlike poles.</p>
D4D-□A□N	2NC (slow-action)		<p>11-12 21-22</p> <p>Stroke →</p> <p>ON</p> <p>NC contacts 11-12 and 21-22 have an approved direct opening mechanism. →</p> <p>Terminals 11-12 and 21-22 can be used as unlike poles.</p>

Note: Terminals are numbered according to EN50013 and contacts are marked according to EN60947-5-1.

Direct Opening Mechanism

1NC/1NO Contact (Slow-action)

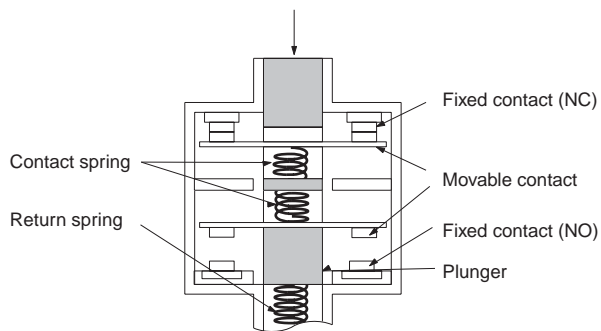

Only the NC contacts have a direct opening function. When metal deposition occurs, the contacts are separated from each other by pushing in the plunger.

Conforms to EN60947-5-1 Direct Opening 

2NC Contact (Slow-action)

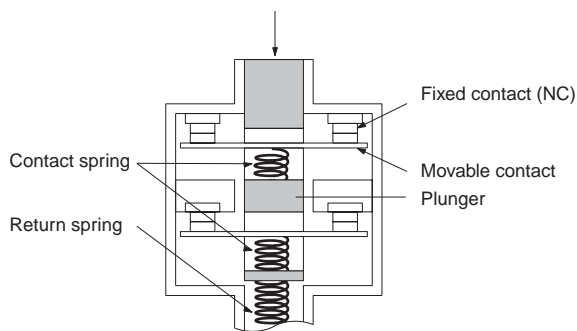

Both NC contacts have a direct opening function. When metal deposition occurs, the contacts are separated from each other by pushing in the plunger.

Conforms to EN60947-5-1 Direct Opening 

Note: The Switches are marked with  indicating approval for the direct opening mechanism.

Nomenclature

Head

With roller lever models, the direction of the switch head can be adjusted to any of the four directions by loosening the roller lever switch screws at the four corners of the head.

Safety-oriented Lever Setting

Grooves which engage the lever every 90° are cut in the operation indicator disk to prevent the lever from slipping against the rotary shaft.

Reset Head (Blue)

The direction of the reset head can be adjusted to any of the four directions.

Built-in Switch

Has a direct opening mechanism separating the contacts when the contacts are welded.

Conduit

Wide switch variations.

Pg13.5: 1-conduit, 2-conduit models
G1/2: 1-conduit, 2-conduit models
1/2-14NPT: 1-conduit models
M20: 1-conduit models

Cover

The cover, with a hinge on its lower part, can be opened by removing the screw of the cover, which ensures ease of maintenance and wiring.

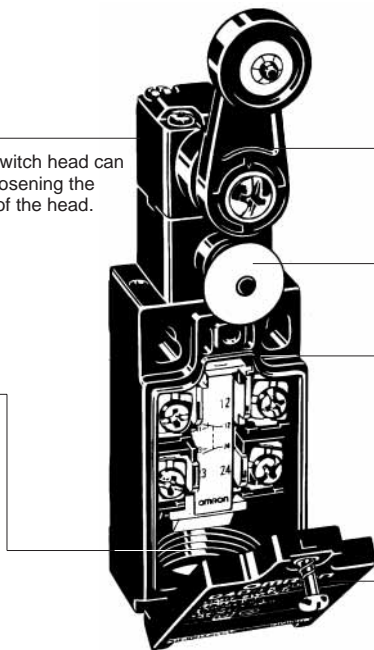

Note: The D4D-R uses NBR.

Dimensions

- Note:**
1. All units are in millimeters unless otherwise indicated.
 2. Unless otherwise specified, a tolerance of ± 0.4 mm applies to all dimensions.
 3. The minimum number of screw threads is five when the Pg13.5 conduit is used and four when the G1/2 conduit is used.

Switches

1-conduit Models

Roller Lever  Safety Limit switch, mechanical form lock

D4D-1520R
D4D-2520R
D4D-4520R
D4D-1A20R
D4D-2A20R

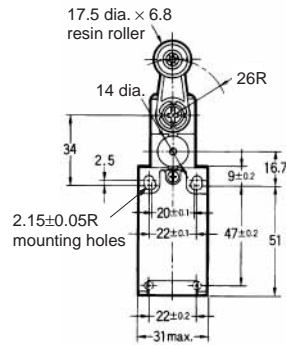
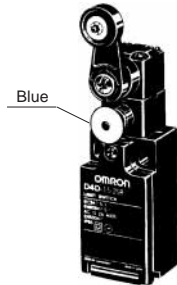

see note 3

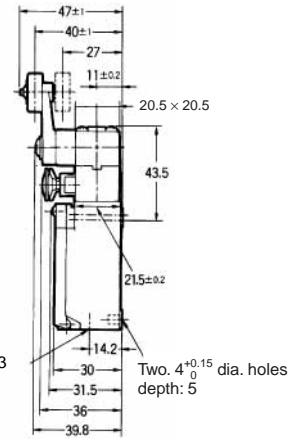

Adjustable Roller Lever

D4D-1521R
D4D-2521R
D4D-4521R
D4D-1A21R
D4D-2A21R

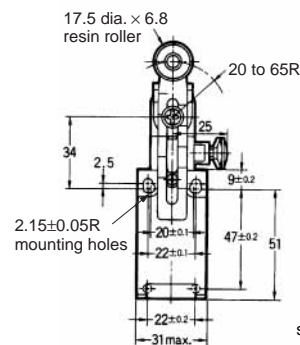
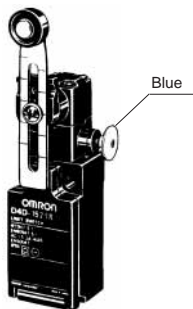

see note 3

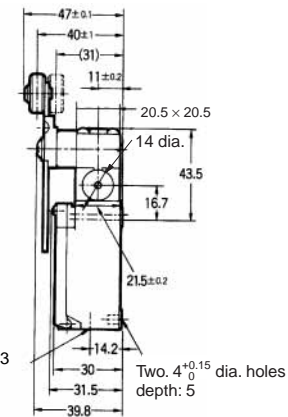

**Adjustable Roller Lever, Form Lock
(Rubber Roller Lever)**

■ Safety Limit switch,
mechanical form lock

- D4D-152HR
- D4D-252HR
- D4D-452HR
- D4D-1A2HR
- D4D-2A2HR
- D4D-4A2HR

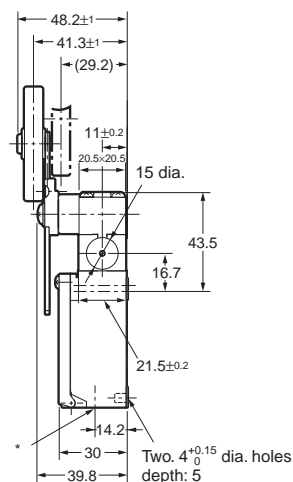
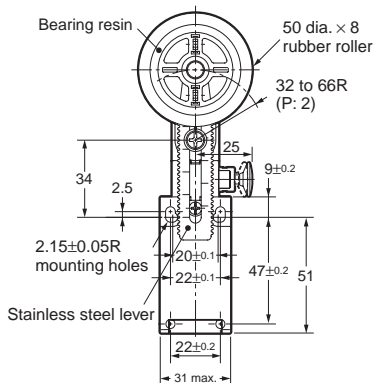
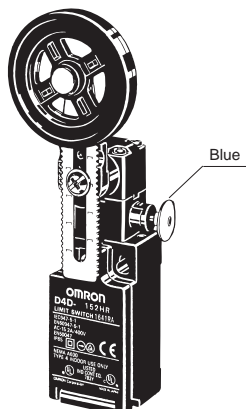

**Adjustable Roller Lever
(Rubber Roller Lever)**

- D4D-1527R
- D4D-2527R
- D4D-4527R
- D4D-1A27R
- D4D-2A27R

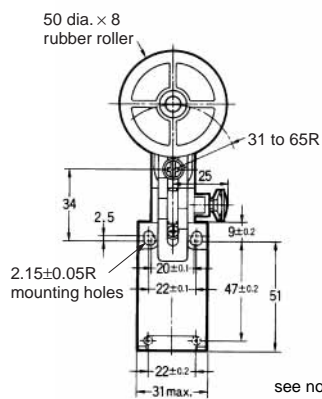
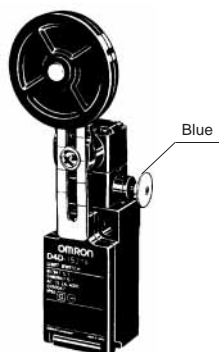

see note 3
on page D-282

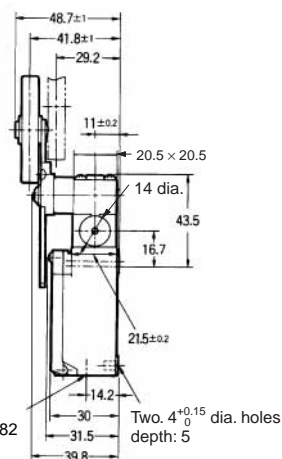

Plunger

- D4D-1531R
- D4D-2531R
- D4D-4531R
- D4D-1A31R
- D4D-2A31R



Safety Limit switch,
mechanical form lock

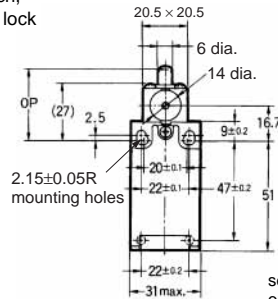

see note 3
on page D-282

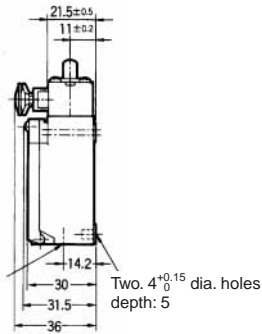

Roller Plunger

- D4D-1532R
- D4D-2532R
- D4D-4532R
- D4D-1A32R
- D4D-2A32R



Safety Limit switch,
mechanical form lock

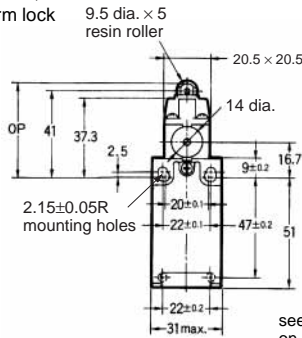

see note 3
on page D-282

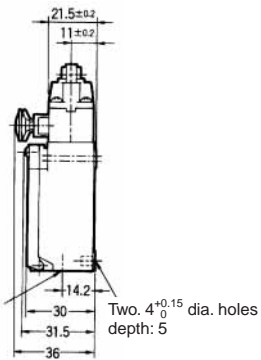

**One-way Roller Arm Lever
(Horizontal)**

- D4D-1562R
- D4D-2562R
- D4D-1A62R
- D4D-2A62R

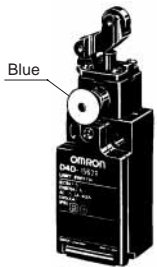

Safety Limit switch,
mechanical form lock

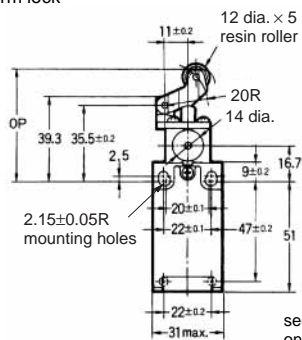

see note 3
on page D-282

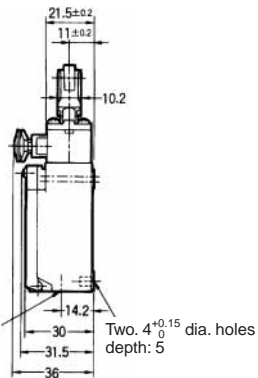

**One-way Roller Arm Lever
(Vertical)**

- D4D-1572R
- D4D-2572R
- D4D-1A72R
- D4D-2A72R



Safety Limit switch,
mechanical form lock

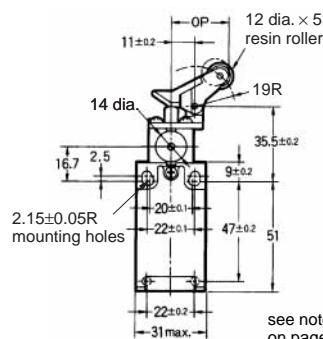

see note 3
on page D-282

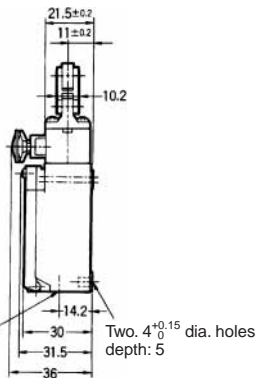

2-conduit Models

Roller Lever
D4D-5520R
D4D-6520R
D4D-5A20R
D4D-6A20R

Safety Limit switch,
 mechanical form lock

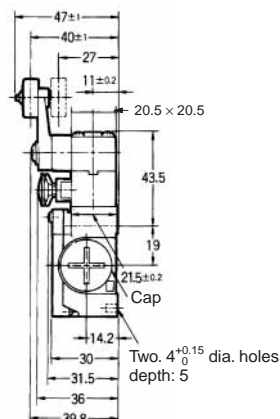
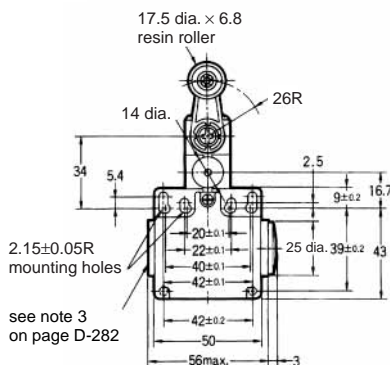
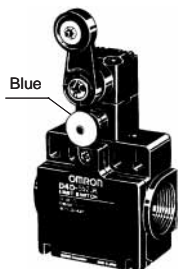

Adjustable Roller Lever

D4D-5521R
D4D-6521R
D4D-5A21R
D4D-6A21R

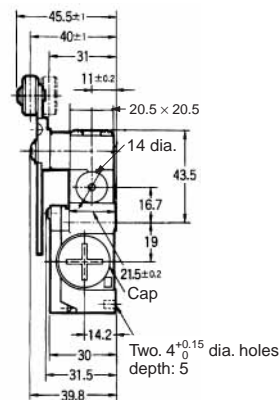
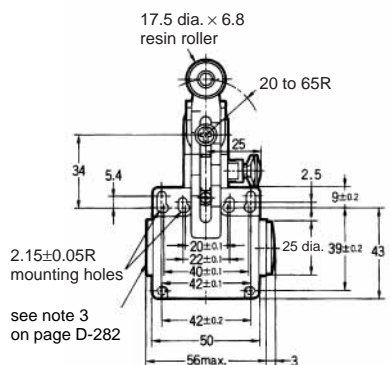
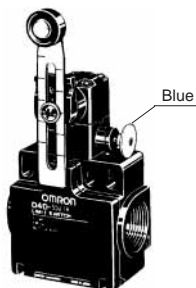

Adjustable Roller Lever (Rubber Roller Lever)

D4D-5527R
D4D-6527R
D4D-5A27R
D4D-6A27R

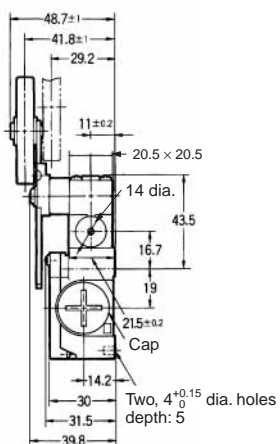
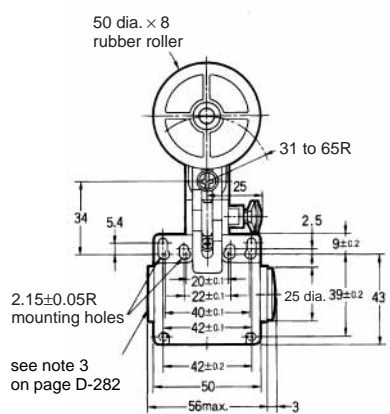
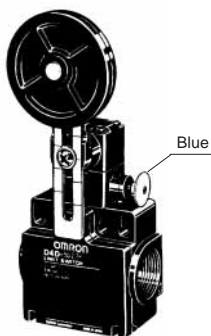

D4D-□R

Plunger

D4D-5531R
D4D-6531R
D4D-5A31R
D4D-6A31R

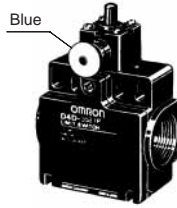

Safety Limit switch,
mechanical form lock

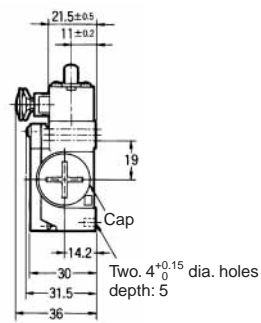
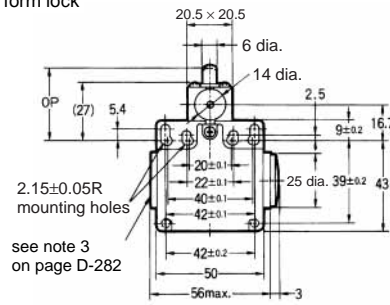

Roller Plunger

D4D-5532R
D4D-6532R
D4D-5A32R
D4D-6A32R

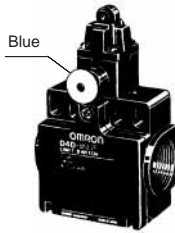

Safety Limit switch,
mechanical form lock

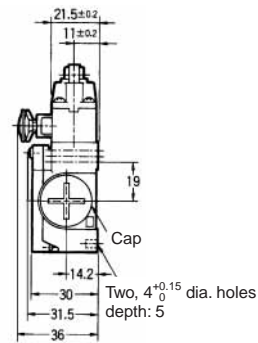
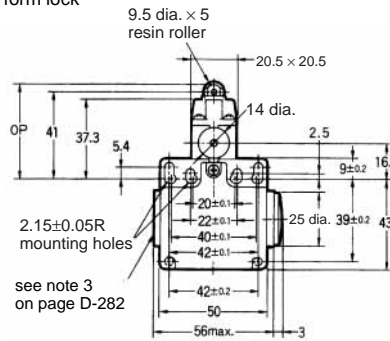

One-way Roller Arm Lever (Horizontal)

D4D-5562R
D4D-6562R
D4D-5A62R
D4D-6A62R

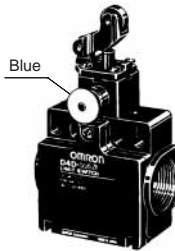

Safety Limit switch,
mechanical form lock

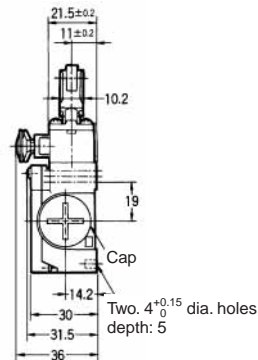
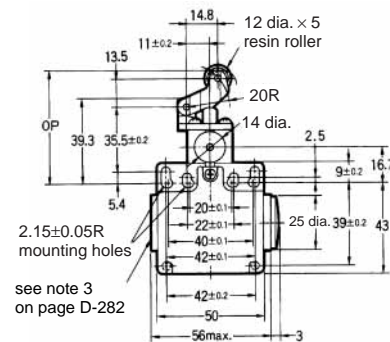

One-way Roller Arm Lever (Vertical)

D4D-5572R
D4D-6572R
D4D-5A72R
D4D-6A72R

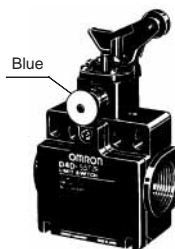

Safety Limit switch,
mechanical form lock

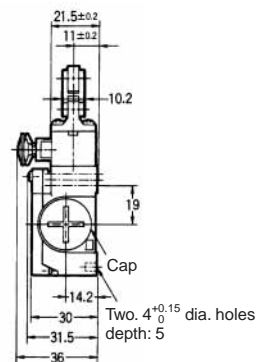
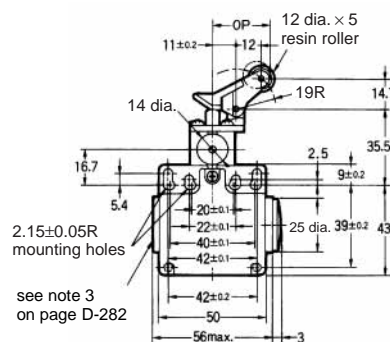

Levers

Refer to the following for the angles and positions of the watchdogs.

**Roller Lever
(D4D-□□20R)**

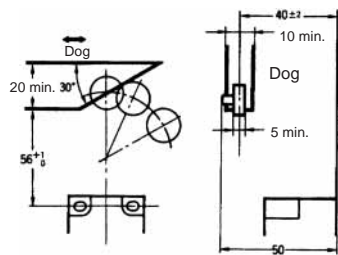

**Adjustable Roller Lever
(D4D-□□21R)**

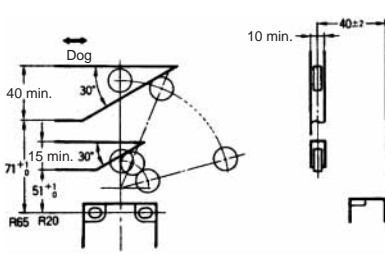

**Adjustable Roller Lever
(Rubber Roller Lever)
(D4D-□□27R)**

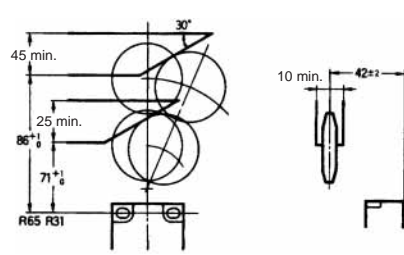

**Sealed Plunger
(D4D-□□31R)**

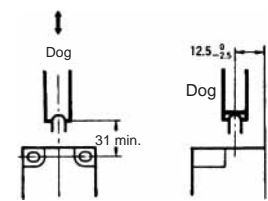

**Roller Plunger
(D4D-□□32R)**

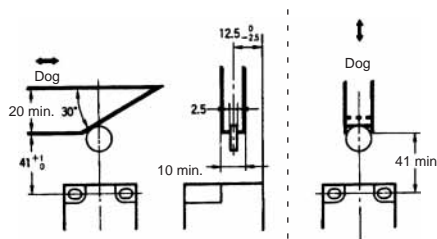

**One-way Roller Arm Lever
(Horizontal)
(D4D-□□62R)**

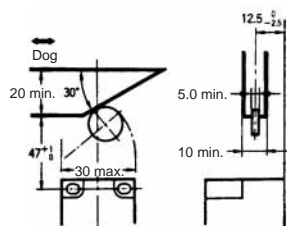

**One-way Roller Arm Lever
(Vertical)
(D4D-□□72R)**

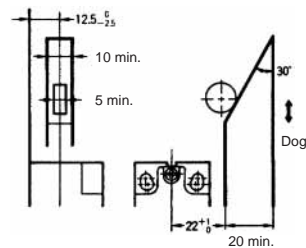

D4D-□R

Precautions

⚠ Caution

Do not use metal connectors or conduits with this Switch. Rigid connectors and conduits may damage the Switch. The broken conduit hole may cause an electrical shock hazard.

If the D4D-□R is applied to a safety category circuit for prevention of injury, use the D4D-□R model that has an NC contact equipped with a direct opening mechanism, and make sure that the D4D-□R operates in the direct opening mode. Furthermore, secure the D4D-□R with screws or equivalent parts that are tightened in a single direction so that the D4D-□R cannot be easily removed. Then provide a protection cover for the D4D-□R and post a warning label near the D4D-□R.

Ensure that the actuator is pushed into the lock position by, for example, setting up a dog. Not doing so may result in the actuator becoming unlocked and causing an accident.

When the Limit Switch locks due to a fault in the system, be sure to reset the Limit Switch manually before resupplying power after confirming the safety of the system.

Be sure to connect a fuse with a breaking current 1.5 to 2 times larger than the rated current to the Limit Switch in parallel in order to protect the Limit Switch from damage due to short-circuiting.

When using the Limit Switch for the EN ratings, use the gI or gG 10-A fuse.

Do not use the Limit Switch as a stopper.

Actuation of the Limit Switch over a long time may deteriorate parts of the Limit Switch and a releasing failure may result. Be sure to check the condition of the Limit Switch regularly.

When using the Limit Switch as a safety component, be sure to check the system design for both operational and circuit safety.

Correct Use

Operating Environment

The Limit Switch is intended for indoor use only. Using the Limit Switch outdoors may result in a malfunction.

Tightening Torque

Be sure to tighten each screw of the D4D-□R properly, otherwise the D4D-□R may malfunction.

No.	Type	Torque
1	M3.5 terminal screw	0.59 to 0.78 N·m
2	Cover mounting screw	0.78 to 0.88 N·m
3	Head mounting screw	0.78 to 0.88 N·m
4	Lever mounting screw	1.57 to 1.77 N·m
5	M4 body mounting screw	0.49 to 0.69 N·m
6	Connector	1.77 to 2.16 N·m 1.37 to 1.77 N·m (see note)
7	Cap screw	1.27 to 1.67 N·m

Note: This torque range applies to 1/2-14NPT connectors.

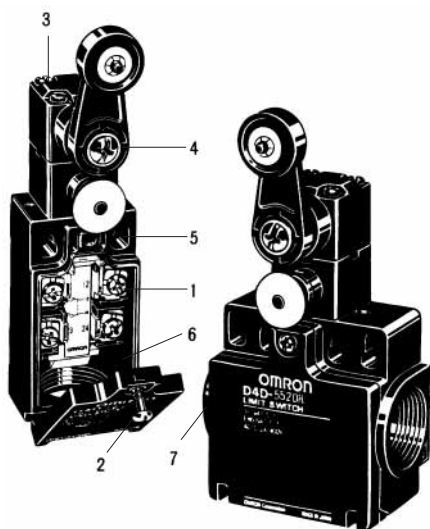

Mounting

Fasten the Switch with two M4 Allen-head bolts and washers. Provide a stud with a diameter of $4_{-0.15}^{-0.05}$ and a height of 4.8 mm max. at two places as shown below so that the Switch is firmly fixed at four points.

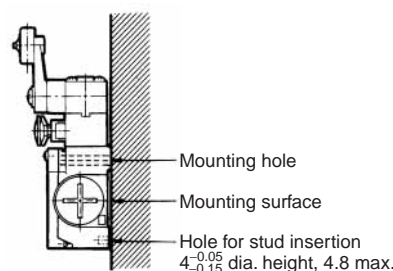

Mounting Holes/Studs

Standard 1-conduit

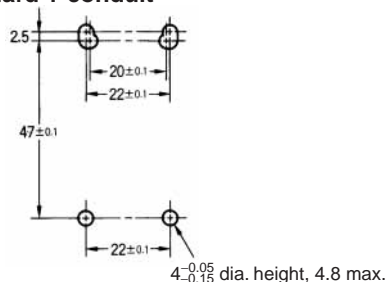

2-conduit

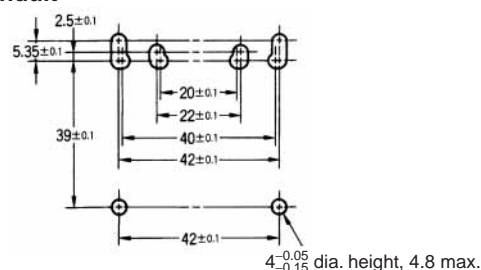

Changing the Head Direction

If the head direction has been changed, check the torque of each screw and make sure that the screws are free of foreign substances, and that each screw is tightened to the proper torque.

Wiring

- Do not connect the bare lead wires directly to the terminals but be sure to connect each of them by using an insulation tube and M3.5 round crimp terminals and tighten each terminal screw within the specified torque range.
- The proper lead wire is 20 to 14 AWG (0.5 to 2.5 mm²) in size.
- Do not touch the terminals while power is being supplied in order to avoid an electrical shock.

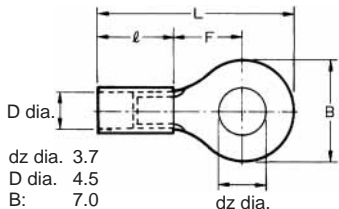

dz dia.	3.7
D dia.	4.5
B:	7.0
L:	20.2
F:	7.7
l:	9.0 (mm)

Perform wiring for the crimp terminals in the orientation shown below, so that they do not rest on the casing or the cover.

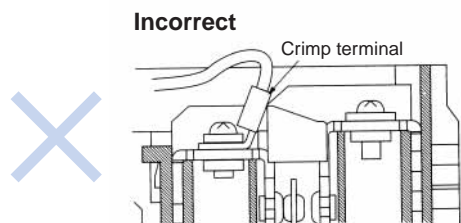
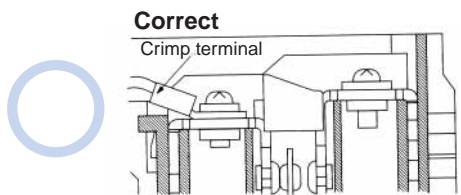
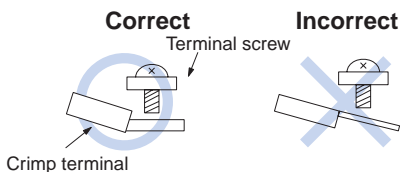

Processing the Conduit Opening

Tighten the connector to a torque of 1.8 to 2.2 N·m (1.37 to 1.77 N·m if it is a 1/2-14NPT). Excessive tightening torque may damage the casing. To satisfy IP65, apply sealing tape to the connector conduit. The diameter of the cable must be suited to the corresponding connector.

Insert a cap screw provided with the D4D-□R into any unused conduit opening of the D4D-□R and tighten the cap screw to a torque of 1.27 to 1.67 N·m.

Maintenance and Repairs

The user must not maintain or repair equipment incorporating any D4D-□R model. Contact the manufacturer of the equipment for any maintenance or repairs required.

Others

With rubber roller lever models, the rubber roller may turn white with the passage of time, but this will not affect the quality of operation.