

Small Safety Limit Switch

D4F

A Smaller Limit Switch than Ever Previously Produced. Ideal for Applications to Small-scale Machinery and Equipment

- A noticeable reduction to 1/4 the size of OMRON's conventional model.
- High-sensitivity safety limit switch.
- Built-in switches with two- or four-contact construction are available.
- Degree of protection: IP67 (EN60947-5-1)
- Patent and design pending.



Features

A Dramatic Reduction in Size

The volume is reduced to one quarter of the volume of our company's conventional types of limit switches (30 (W) × 18 (L) × 60 mm (H)).

Optimal for the downsizing of machinery and equipment.

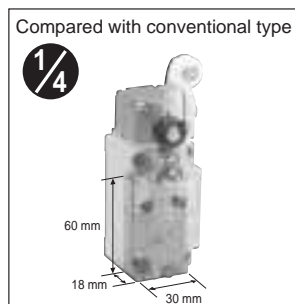

Four-contact Construction is Available

D4F models of two-contact construction (1NC/1NO and 2NC) and those of four-contact construction (2NC/2NO and 4NC) are available.

The auxiliary contact can be used for monitoring input of control circuits and indicator lighting.

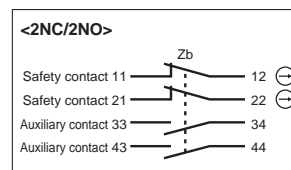

High-sensitivity and Space-saving

The conventional types of limit switches with a direct opening mechanism required 18 degrees for a movement until operation because its direct opening point is long (Our company's conventional types of limit switches).

The D4F requires 6 degrees to respond.

On the table that allows machine tools etc. to move at an increasing speed, the moment the dog pushes the actuator, the D4F responds. With the development of smaller versions of machines, the D4F saves space and fits in a smaller space.

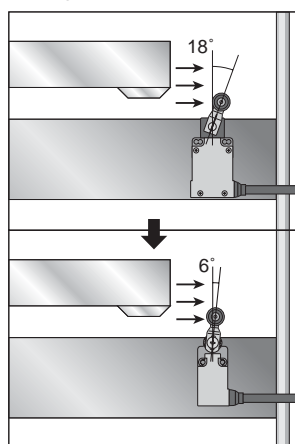

Positioning in Steps of 9 Degrees

For a roller lever type of switch, grooves are incised on the body and the cam of the actuator, to allow positioning in steps of 9 degrees.

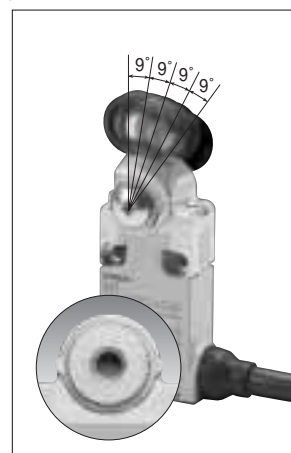

Standards and EC Directives

- Conforms to the following EC Directives:
Machinery Directive
Low Voltage Directive
EN60204-1
EN1088
EN50047
EN81
EN115
GS-ET-15
JIS C 8201-5-1

Approved Standards

Agency	Standards	File No.
TÜV Product service	EN60947-5-1 (Direct opening: approved)	(See note 1.)
UL (See note 2.)	UL508 CSA C22.2 No.14	E76675

- Note: 1. Contact your Omron sales representative.
2. Approval has been obtained for CSA C22.2 No. 14 under UL.



Ordering Information

Model Number Legend

D4F-oo-oo
1 2 3 4

- | | | | |
|---|---|--|--|
| 1. Built-in Switch
1: 1NC/1NO (slow-action)
2: 2NC (slow-action)
3: 2NC/2NO (slow-action)
4: 4NC (slow-action) | 2. Actuator
02: Roller plunger
(Metallic roller)
20: Roller lever
(Metallic lever, resin roller) | 3. Cable Length
1: 1 m
3: 3 m
5: 5 m | 4. Pull-outing direction of cable
R: Horizontal
D: Vertical |
|---|---|--|--|

List of Models

Actuator	Cable length	Cable direction	Built-in switch			
			1NC/1NO (slow-action)	2NC (slow-action)	2NC/2NO (slow-action)	4NC (slow-action)
Roller lever (Metallic lever, resin roller) 	1 m	Horizontal	D4F-120-1R	D4F-220-1R	D4F-320-1R	D4F-420-1R
		Vertical	D4F-120-1D	D4F-220-1D	D4F-320-1D	D4F-420-1D
	3 m	Horizontal	D4F-120-3R	D4F-220-3R	D4F-320-3R	D4F-420-3R
		Vertical	D4F-120-3D	D4F-220-3D	D4F-320-3D	D4F-420-3D
	5 m	Horizontal	D4F-120-5R	D4F-220-5R	D4F-320-5R	D4F-420-5R
		Vertical	D4F-120-5D	D4F-220-5D	D4F-320-5D	D4F-420-5D
Roller plunger (Metallic roller) 	1 m	Horizontal	D4F-102-1R	D4F-202-1R	D4F-302-1R	D4F-402-1R
		Vertical	D4F-102-1D	D4F-202-1D	D4F-302-1D	D4F-402-1D
	3 m	Horizontal	D4F-102-3R	D4F-202-3R	D4F-302-3R	D4F-402-3R
		Vertical	D4F-102-3D	D4F-202-3D	D4F-302-3D	D4F-402-3D
	5 m	Horizontal	D4F-102-5R	D4F-202-5R	D4F-302-5R	D4F-402-5R
		Vertical	D4F-102-5D	D4F-202-5D	D4F-302-5D	D4F-402-5D

Specifications

Approved Standard Ratings

TÜV (EN60947-5-1)

Item	Utilization category	AC-15	DC-13
Rated operating current (Ie)		0.75 A	0.27 A
Rated operating voltage (Ue)		240 V	250 V

Note: Use a 10-A fuse type gI or gG that conforms to IEC269 as a short-circuit protection device.

UL/CSA (UL508, CSA C22.2 No. 14)

C300

Rated voltage	Carry current	Current		Volt-amperes	
		Make	Break	Make	Break
120 VAC	2.5 A	15 A	1.5 A	1,800 VA	180 VA
240 VAC		7.5 A	0.75 A		

Q300

Rated voltage	Carry current	Current		Volt-amperes	
		Make	Break	Make	Break
125 VDC	2.5 A	0.55 A	0.55 A	69 VA	69 VA
250 VDC		0.27 A	0.27 A		

Characteristics

Degree of protection (See note 1.)	IP67 (EN60947-5-1)
Durability (See note 2.)	Mechanical: 10,000,000 times min. Electrical: 1,000,000 times min. (4-mA resistive load at 24 VDC, 4 circuits) 150,000 times min. (1-A resistive load at 125 VAC, 2 circuits / 4-mA resistive load at 24 VDC, 2 circuits) (See note 3.)
Operating speed	1 mm to 0.5 m/s
Operating frequency	Mechanical: 120 operations/minute Electrical: 30 operations/minute
Insulation resistance	100 MΩ min. (at 500 VDC) between terminals of the same polarities, between terminals of different polarities, between current-carrying metal parts and grounds, and between each terminal and non-current carrying metal parts
Minimum applicable load (See note 4.)	4-mA resistive load at 24 VDC, 4 circuits (Level N reference value)
Contact resistance (See note 5.)	300 mΩ max. (initial value with 1-m cable), 500 mΩ max. (initial value with 3-m cable), 700 mΩ max. (initial value with 5-m cable)
Dielectric strength	Between terminals of same polarities: Uimp 2.5 kV (EN60947-5-1) Between terminals of different polarities: Uimp 4 kV (EN60947-5-1) Between current-carrying metal parts and grounds: Uimp 4 kV (EN60947-5-1) Between each terminal and non-current carrying metal parts: Uimp 4 kV (EN60947-5-1)
Conditional short-circuit current	100 A (EN60947-5-1)
Pollution degree (operating environment)	3 (EN60947-5-1)
Conventional free air thermal current (Ith)	2.5 A (EN60947-5-1)
Protection against electric shock	Class I (with a ground wire)
Vibration resistance	Malfunction 10 to 55 Hz, 0.75-mm single amplitude
Shock resistance	Destruction 1,000 m/s ² min.
	Malfunction 300 m/s ² min.
Ambient temperature	Operating: -30°C to 70°C (with no icing)
Ambient humidity	Operating: 95% max.
Cable	UL2464 No. 22 AWG, finishing O.D.: 8.3 mm
Weight	Approx. 190 g (D4F-102-1R, with 1-m cable) Approx. 220 g (D4F-120-1R, with 1-m cable)

- Note:
1. The degree of protection shown above is based on the test method specified in EN60947-5-1. Be sure to confirm in advance the sealing performance under the actual operating environment and conditions.
 2. Durability values are calculated at an operating temperature of 5°C to 35°C, and an operating humidity of 40% to 70%. Contact your OMRON sales representative for more detailed information on other operating environments.
 3. When the ambient temperature is 35°C or higher, do not apply 1 A at 125 VAC to more than two circuits.
 4. The value will vary depending on factors such as the switching frequency, the ambient environment, and the reliability level. Be sure to confirm correct operation with the actual load before application.
 5. The contact resistance was measured with 0.1 A at 5 to 8 VDC with a fall-of-potential method.

Operating Characteristics

Slow-action (1NC/1NO, 2NC, 2NC/2NO, and 4NC)

Operating Characteristics	Model	D4F- \circ 20- \circ R D4F- \circ 20- \circ D	D4F- \circ 02- \circ R D4F- \circ 02- \circ D
Operating force max.: OF (See note 1.)		5 N	12 N
Release force min.: RF (See note 2.)		0.5 N	1.5 N
Pretravel: PT1 (11-12 and 21-22)		6±3° (NC)	1 mm max. (NC)
: PT1 (31-32 and 41-42)		9±3° (NC)	1.3 mm max. (NC)
: PT2 (See note 3.)		(12°) (NO)	(1.2 mm) (NO)
Overtravel min.: OT		40°	3.2 mm
Operating position: OP (11-12 and 21-22)		—	29.4±1 mm
: OP (31-32 and 41-42)		—	29±1 mm
Total travel: TT (See note 3.)		(55°)	(4.5 mm)
Min. direct opening travel: DOT (See note 4.)		18°	1.8 mm
Min. direct opening force: DOF		20 N	20 N

- Note:
1. The OF value is the maximum load that opens an NC contact (11-12, 21-22, 31-32, 41-42).
 2. The RF value is the minimum load that closes an NC contact (11-12, 21-22, 31-32, 41-42).
 3. The PT2 and TT values are reference values.
 4. The D4F is used in accordance with EN81 and EN115 at a minimum DOT of 30° and 2.8 mm.

Nomenclature

Lever

Improved safety of the lever-setting (Form lock configuration). Many grooves are incised on the lever and the rotating shaft that mesh with each other to prevent a slip between the lever and the rotating shaft. The lever can be set for positioning in steps of 9 degrees.

Built-in Switch

Has a direct opening mechanism separating the contacts when the NC contacts are welded.

Head

The plunger type of actuator can be used in a normal direction and reverse direction.

Cable

The cable can be pulled out in a horizontal direction or in a vertical direction.

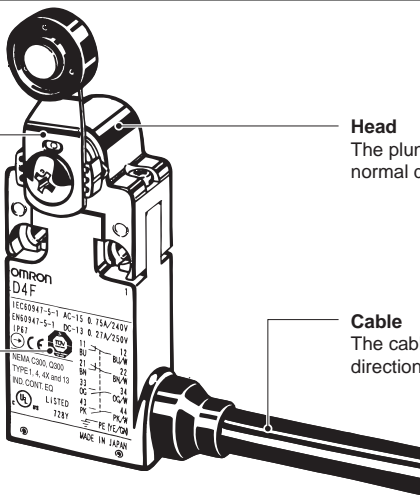

Operation

Contact Form

Model	Contact	Diagram	Remarks
D4F-1o-oo	1NC/1NO (slow-action) 		Only NC contact 11-12 has an approved direct opening mechanism. (→) The terminals 11-12 and 33-34 can be used as unlike poles.
D4F-2o-oo	2NC (slow-action) 		NC contacts 11-12 and 21-22 have an approved direct opening mechanism. (→) The terminals 11-12 and 21-22 can be used as unlike poles.
D4F-3o-oo	2NC/2NO (slow-action) 		NC contacts 11-12 and 21-22 have an approved direct opening mechanism. (→) The terminals 11-12, 21-22, 33-34 and 43-44 can be used as unlike poles.
D4F-4o-oo	4NC (slow-action) 		NC contacts 11-12, 21-22, 31-32 and 41-42 have an approved direct opening mechanism. (→) The terminals 11-12, 21-22, 31-32 and 41-42 can be used as unlike poles.

Direct Opening Mechanism
1NC/1NO Contact (slow-action)

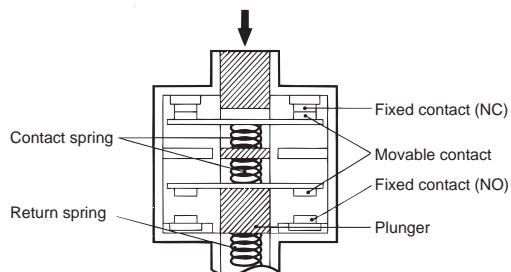

Conforms to EN60947-5-1 Direct Opening (→).
(Only the NC contacts have a direct opening function.)
When metal weld occurs, the NC contacts are separated from each other by pushing in the plunger.

D4F

Dimensions

- Note: 1. All units are in millimeters unless otherwise indicated.
 2. Each dimension has a tolerance of 0.4 mm unless otherwise specified.

Roller lever (Metallic lever, resin roller)
D4F-o20-oR

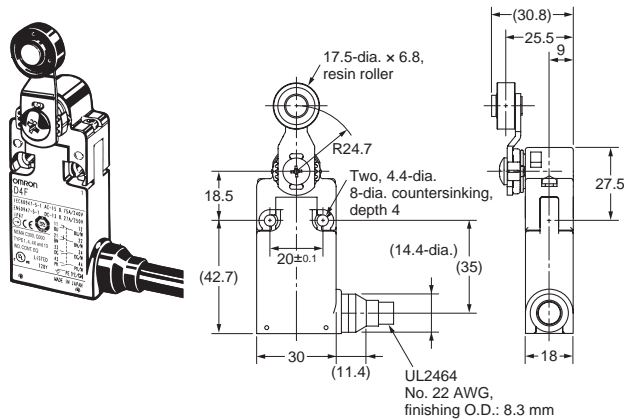

Roller plunger (Metallic roller)
D4F-o02-oR

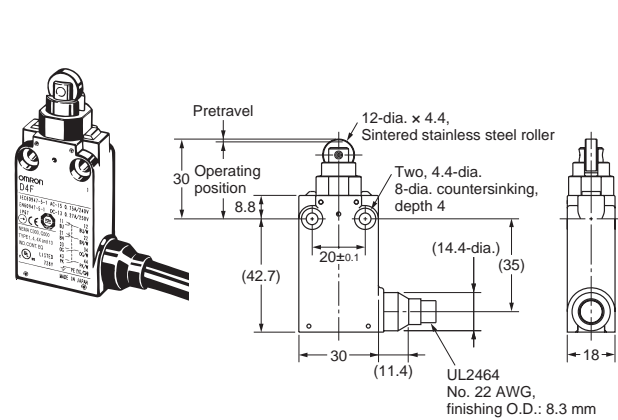

Roller lever (Metallic lever, resin roller)
D4F-o20-oD

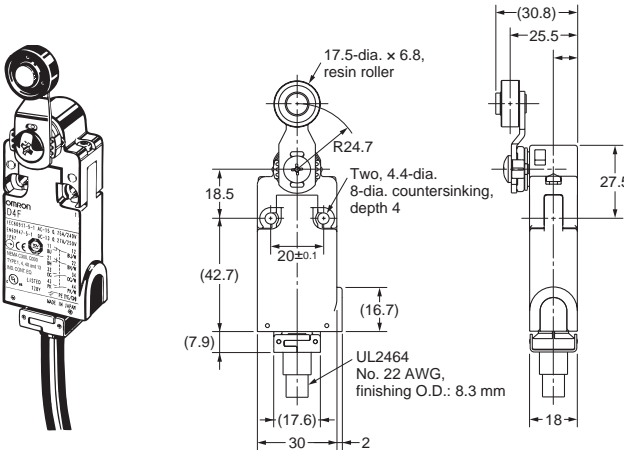

Roller plunger (Metallic roller)
D4F-o02-oD

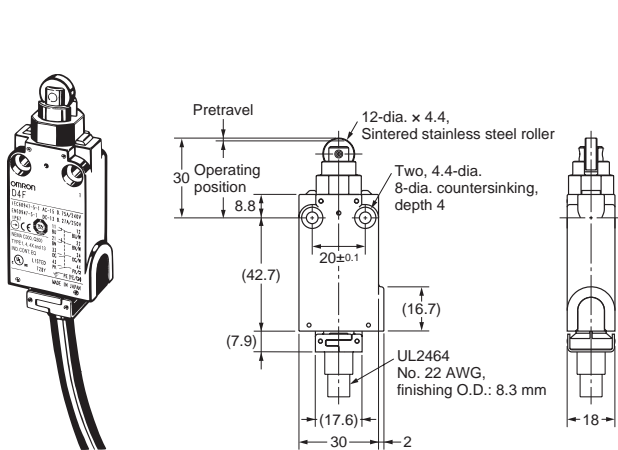

Precautions

NOTICE

Be sure to connect a ground line, otherwise an electric shock may occur.

If the D4F is to be used as a switch in an emergency stop circuit or in a safety circuit for preventing accidents resulting in injuries or deaths, use NC contacts with a forced release mechanism and set the D4F so that it will operate in direct opening mode.

For safety, install the Switch using one-way rotational screws or other similar means to prevent it from easily coming off. Protect the D4F with an appropriate cover and post a warning sign near the D4F in order to ensure the safety.

To prevent the D4F from damage due to circuit short-circuiting, connect a fuse with a breaking current 1.5 to 2 times larger than the rated current of the D4F in series to the D4F.

If the D4F is used under EN-approved conditions, use a gI or gG 10-A fuse approved by IEC269.

Actuation of the Switch over a long time may deteriorate parts of the Switch and a return failure may result. Be sure to check the condition of the Switch regularly.

Do not supply electric power when wiring.

Do not use the Switch where explosive gas, flammable gas, or any other dangerous gas may be present.

Keep the electrical load below the rated value.

Never wire to a wrong terminal.

Be sure to evaluate the Switch under actual working conditions after installation.

Do not drop or disassemble the D4F.

Do not use in closely contacted mounting.

Do not use the Switch as a stopper.

Conduct periodic inspections.

Do not use it in an activating circuit. (Use it as a safety signal.)

Contacts of the D4F can be used both for ordinary load and microload; however, once the contact is opened or closed with an ordinary load, it cannot be used for a load smaller than that. The contact surface may be rough, which impairs the reliability of contacting.

Handling of cables

Cables cannot be flexed repeatedly.

The cable is fixed with sealing materials on the bottom of the switch. When excessive force may be imposed on the cable, fasten the cable with a fixing unit at a distance of 50 mm from the bottom of the switch as shown.

Do not pull or press the cable at an excessive force (50 N max.).

When bending the cable, secure the cable with more than 45-mm bending radius so as not to cause damage to the insulator or sheath of the cable. Doing so may result in current leakage or burning.

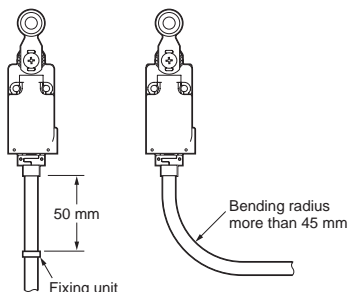

When wiring, be sure to prevent penetration of a liquid such as water or oil through the cable end.

Operating Environment

Keep the D4F away from oil and water, as these may enter the casing. (Though the switch construction complies with IP67 and prevents immersion of water even when held in water for a specified time, its use is not guaranteed when it is immersed in a liquid.)

Make sure in advance that the environment is suitable, with the presence of oil, water, or chemicals, as these may cause the seal to deteriorate, resulting in faulty contact, faulty isolation, current leakage, or burning.

Do not use the D4F in the following locations:

- Locations subject to corrosive gas
- Locations with severe changes in temperature
- Locations with excessive humidity that may cause condensation
- Locations with excessive vibration
- Locations that may be covered with processing chips or dust
- Locations subject to high temperature or excessive humidity

Correct Use

Operating Environment

The D4F is for indoor use only.

Do not use the D4F outdoors. Otherwise, the D4F may malfunction.

Durability

The life of the D4F will vary with the switching conditions. Before applying the D4F, test the D4F under actual operating conditions and be sure to use the D4F in actual operation within switching times that will not lower the performance of the D4F.

Tightening Torque

Be sure to tighten each screw of the D4F properly, otherwise the D4F may soon malfunction.

No.	Type	Proper tightening torque
1	Lever mounting screw (M5)	2.4 to 2.8 N-m
2	Body mounting screw (M4)	1.18 to 1.37 N-m

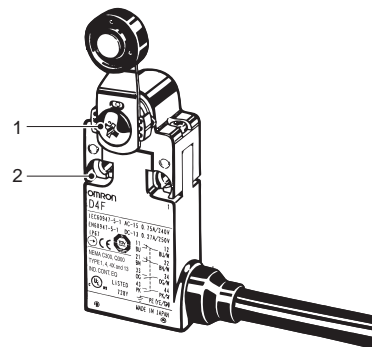

Mounting

Use two M4 screws and washers to mount the D4F securely. The D4F can be mounted more securely with proper tightening torque.

Mounting Holes (Unit: mm)

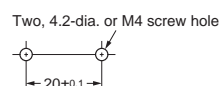

Changing the lever angle

Unfasten the screw that holds the lever to set the position of the lever at any angle through 360° (in steps of 9°).

After unfastening the screws that hold the lever, mount the lever the other way (normal side or reverse side). Set an angle of the lever to complete adjustment within a range in which the lever does not touch the switch body.

Wiring

Identifying Wires

Identify wires according to the color (with or without white lines) of the insulation on the wire.

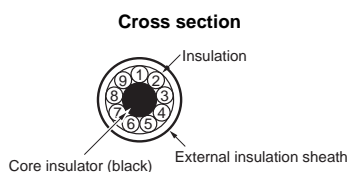

Wire Colors

No.	Color of insulation	No.	Color of insulation
1	Blue/white	6	Brown
2	Orange /white	7	Pink
3	Pink/white	8	Orange
4	Brown/white	9	Blue
5	Green/yellow		

Note: "Blue/white, orange/white, pink/white, or brown/white" means that the cover is blue, orange, pink, or brown with a white line.

Terminal Numbers

Identify terminal numbers based on the color (with or without white lines) of the insulation on the wire.

The safety and auxiliary contacts of D4F models of four-terminal contact construction and those of two-terminal contact construction are described below.

The safety contacts are direct-opening NC contacts (11-12 and 21-22); they are used for safety circuits, and each of them is indicated with the appropriate mark (⊖).

Auxiliary contacts are used to check (to monitor) the operating state of the switch, which are equivalent to NO contacts (33-34 and 43-44) or NC contacts (31-32 and 41-42).

The NC contacts 31-32 and 41-42 of auxiliary contacts (orange or pink) can be used as safety contacts.

<1NC/1NO>

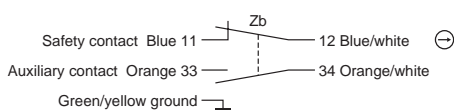

<2NC>

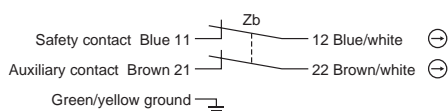

<2NC/2NO>

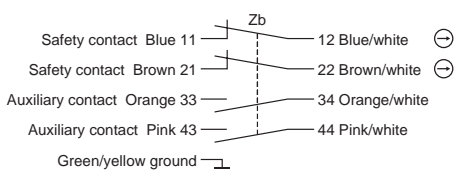

To fully comply with international standards, this catalogue is based on the International System of Units (SI).

<4NC>

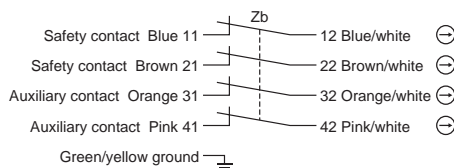

Cut the black core insulator and all unused wires at the end of the external insulation sheath when wiring the cable.

Operating

To set the plunger stroke correctly, press-fit the plunger until the top of the pushing surface comes between two grooves on the plunger.

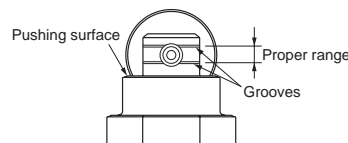

To set the roller lever stroke correctly, push the dog and cam until the lance point comes within the range of the convex part that is the correct setting position.

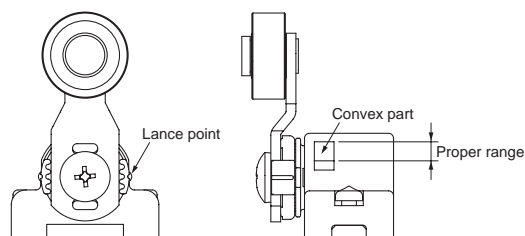

Others

Actuating the switch from an angle other than 90 degrees to the switch face may deform or damage the actuator, or deform or damage the rotary spindle, so make sure that the dog is straight.

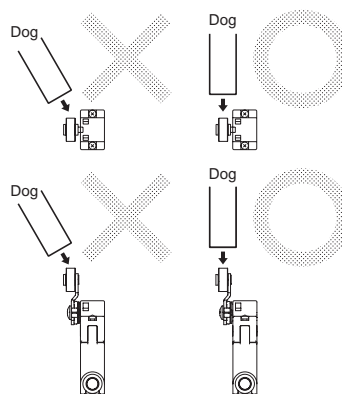

Do not remove the head. Otherwise, a failure may occur.

To avoid telegraphing, take the following precautions.

1. Set the switch to operate in one direction.
2. Modify the rear end of the dog to an angle of 15° to 30° as shown below or to a secondary-degree curve.



3. Modify the circuit so as not to detect the wrong operating signals.

SI Units Conversion Table