

Photomicrosensor

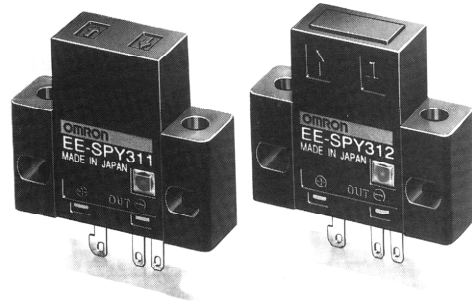

EE-SPY311/
411/312/412

Accurately Detects Objects Placed in Front of Shiny Background

- A shiny background can be used as long as the distance between the sensor and the background is 20 mm or more.
- Detects a minute object such as a 0.05-mm-dia. pure copper wire.
- Small dispersion in sensing distance.
- Light modulation effectively reduces external light interference.



Ordering Information

Appearance	Sensing method	Sensing distance	Output configuration	Model	Weight
Horizontal type 	Convergent reflective type	2 to 6 mm (rated sensing distance: 5 mm)	Light-OFF	EE-SPY311	Approx. 2.6 g
			Light-ON	EE-SPY411	
Vertical type 			Light-OFF	EE-SPY312	
			Light-ON	EE-SPY412	

Specifications

■ Ratings

Item	EE-SPY311, EE-SPY411, EE-SPY312, EE-SPY412
Supply voltage	5 to 24 VDC $\pm 10\%$, ripple (p-p): 5% max.
Current consumption	Average: 15 mA max.; Peak: 50 mA max.
Rated sensing distance	2 to 6 mm (rated sensing distance: 5 mm, white paper with a reflection factor of 90%)
Differential distance	0.2 mm (with a sensing distance of 3 mm, horizontally)
Control output	At 5 to 24 VDC: 80-mA load current (I_C) with a residual voltage of 1.0 V max. 10-mA load current (I_C) with a residual voltage of 0.4 V max.
Indicator	Light indicator (red)
Response frequency (see note)	100 Hz
Connecting method	Dedicated connector: EE-1009, EE-1010
Minimum sensing object	Pure copper wire (0.05 mm dia.)
Possible background	20 mm (glass with aluminum deposition)

Note: The response frequency was measured by detecting the following rotating disks.

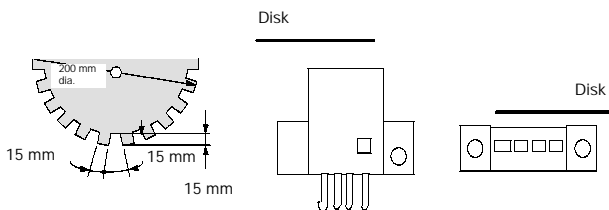

■ Characteristics

Ambient illumination		Sensing face: 3,000 lx max. (incandescent light and sunlight)
Enclosure ratings		IEC IP50 (except the terminal section)
Ambient temperature		Operating: -10° to 55°C
Vibration resistance		Destruction: 10 to 55 Hz, 1.5-mm double amplitude for 2 hrs each in X, Y, and Z directions
Shock resistance		Destruction: 500 m/s ² (approx. 50G) for 3 times each in X, Y, and Z directions
Cable		2 m max. (AWG22 min.)
Ambient humidity		5% to 85%
Material	Case	Polycarbonate
	Holder	Polybutylene phthalate (PBT)

Engineering Data

Operating Range (Typical)

EE-SPY311/411

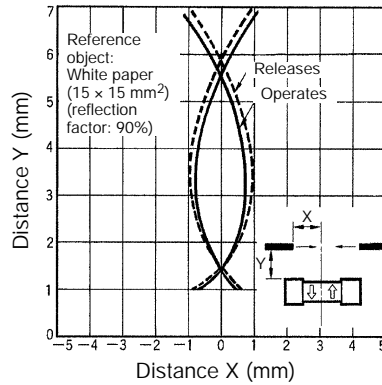

EE-SPY311/411

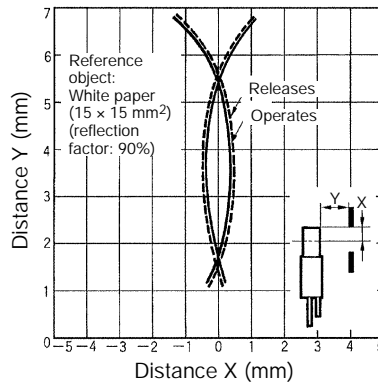

EE-SPY312/412

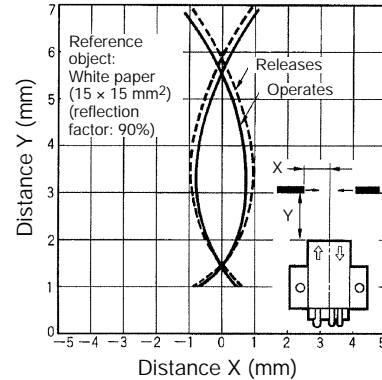

EE-SPY312/412

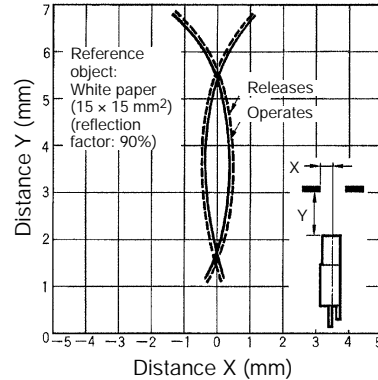

Sensing Distance vs. Object Area (Typical)

EE-SPYj j j

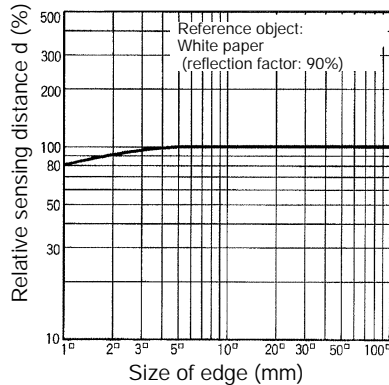

Sensing Angle vs. Sensing Distance (Typical)

EE-SPY312/412

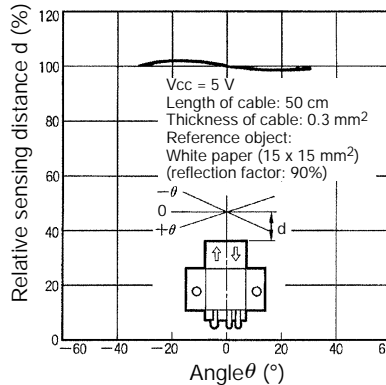

Receiver Output vs. Sensing Distance (Typical)

EE-SPYj j j

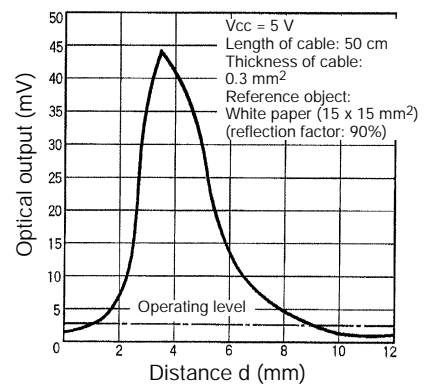

Operation

Output Circuit Diagrams

Light ON/OFF

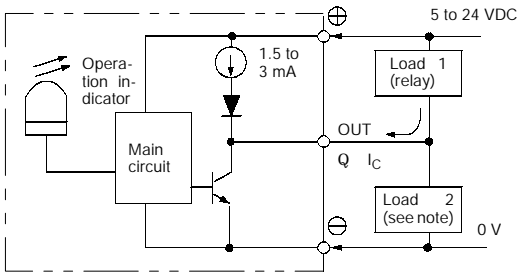

Note: Voltage output (when the sensor is connected to a transistor circuit).

Timing Chart

EE-SPY411/412

Light ON

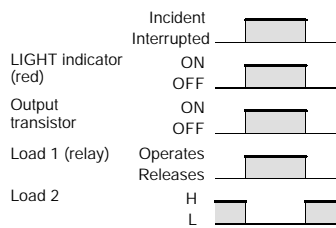

EE-SPY311/312

Light OFF

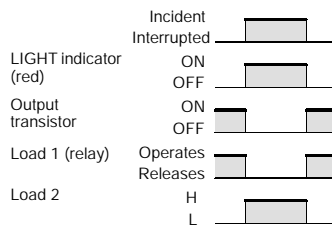

Dimensions

Note: All units are in millimeters unless otherwise indicated.

EE-SPY311
EE-SPY411

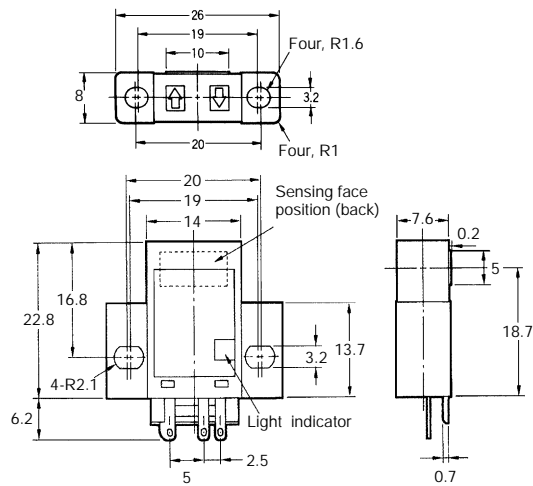
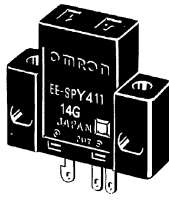

EE-SPY312
EE-SPY412

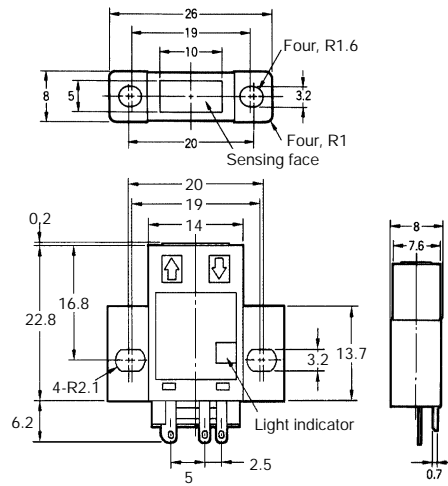
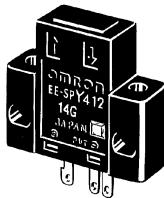

Applicable Connectors

EE-1009/1010

Refer to page 70 for details.

Precautions

Refer to page NO TAG, *Precautions* in *Technical Information*, for general precautions.

Wiring

A cable with a thickness of AWG22 min. and a length of 2 m max. must be connected to the output terminals.

To use a cable longer than 2 m, attach a capacitor with a capacitance of approximately 10 μ F to the wires as shown below (the distance between the terminal and the capacitor must be within 2 m):

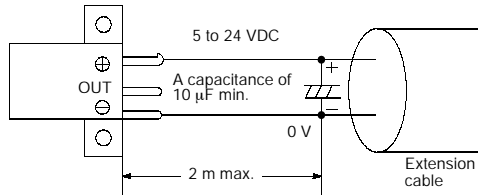

Do not impose excessive force on the terminals (refer to the diagram below). Excess force will damage the terminals.

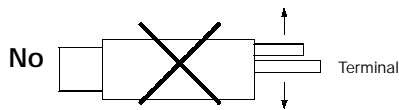

Do not disconnect the connector from the photomicrosensor or wire the leads while the power is on or sensor damage could result.

Wire as shown by the following illustration to connect a small inductive load (a relay for example) to the photomicrosensor. A diode must be connected parallel to the relay to absorb the reverse voltage.

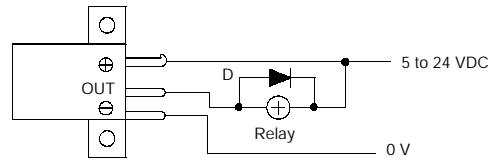

ALL DIMENSIONS SHOWN ARE IN MILLIMETERS.
To convert millimeters into inches, multiply by 0.03937. To convert grams into ounces, multiply by 0.03527.