

## Photomicrosensor

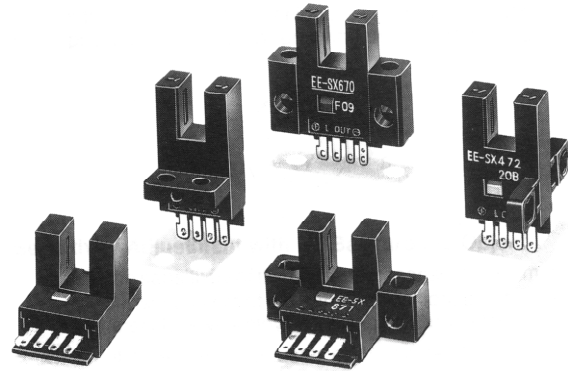



EE-SX670(A)/  
470

### Photomicrosensor with 100-mA Switching Capacity that can be Built into Equipment

- Standard, L-shaped, T-shaped, and close mount-  
ing: 5-series models available.
- Select from fifteen output variations, including  
Light-ON or Light-OFF/ON models.
- Response frequency as high as 1 kHz.
- Easy operation monitoring with bright light  
indicator.
- Wide operating voltage range (5 to 24 VDC) makes  
smooth connection of the photomicrosensor with  
TTLs, relays, and programmable controllers (PC)  
possible.
- Dust-proof slit.
- EE-SX670A/671A/672A/673A/674A models come  
with a Light-OFF indicator, which lights when an  
object is detected.



## Ordering Information

Appearance	Sensing method	Sensing distance	Output configuration	Model	Weight
 Standard	Transmissive type (channel-type)	5 mm (channel width)	Light-OFF/ON (see note 1)	*EE-SX670	Approx. 3.1 g
			Light-ON	*EE-SX470	
 L-shaped			Light-OFF/ON (see note 1)	*EE-SX671	Approx. 3.0 g
			Light-ON	*EE-SX471	
 T-shaped			Light-OFF/ON (see note 1)	*EE-SX672	Approx. 2.4 g
			Light-ON	*EE-SX472	
 Close-mounting			Light-OFF/ON (see note 1)	*EE-SX673	Approx. 2.3 g
			Light-ON	*EE-SX473	
 Close-mounting			Light-OFF/ON (see note 1)	EE-SX674	Approx. 3.0 g
			Light-ON	EE-SX474	
			Light-OFF/ON (see note 1)	EE-SX674A (see note 2)	

- Note:**
1. The Light-OFF/ON models can be used as Light-ON models when the L terminal and positive (+) terminal are short-circuited. A L terminal and positive (+) terminal short circuit Connector (EE-1001-1) is available.
  2. These models are fitted with a LIGHT OFF indicator light.

# Specifications

## ■ Ratings

Item	Standard	L-shaped	T-shaped	Close-mounting
	EE-SX670(A), EE-SX470	EE-SX671(A), EE-SX471	EE-SX672(A), EE-SX472	EE-SX673(A), EE-SX473, EE-SX674(A), EE-SX474
Supply voltage	5 to 24 VDC $\pm 10\%$ , ripple (p-p): 10% max.			
Current consumption	35 mA max.			
Standard reference object	Opaque: 2 x 0.8 mm			
Sensing distance	5 mm			
Differential distance	0.025 mm			
Control output	At 5 to 24 VDC: 100-mA load current ( $I_C$ ) with a residual voltage of 0.8 V max. 40-mA load current ( $I_C$ ) with a residual voltage of 0.4 V max.			
Indicator (see note 1)	Light indicator (red)			
Response frequency (see note 2)	1 kHz max. (3 kHz average)			
Connecting method	Dedicated connectors: EE-1009/1006(A)/1010/1001-01/1001; direct soldering			
Light source	GaAs infrared LED with a peak wavelength of 940 nm			
Receiver	Si phototransistor with a sensing wavelength of 850 nm max.			

Note: 1. The indicator is GaP red LED (peak emission wavelength: 690 nm).

2. The response frequency was measured by detecting the following rotating disks.

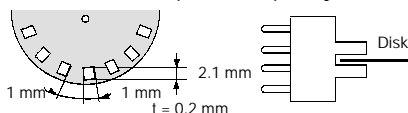

## ■ Characteristics

Ambient illumination (see note)	Fluorescent light: 1,000 lx max.
Enclosure ratings	IEC IP50
Ambient temperature	Operating: $-25^{\circ}$ to $55^{\circ}$ C Storage: $-30^{\circ}$ to $80^{\circ}$ C
Ambient humidity	Operating: 5% to 85% Storage: 5% to 95%
Vibration resistance	Destruction: 20 to 2,000 Hz, (with a peak acceleration of 10G), 1.5-mm double amplitude for 2 hrs (with 4-minute cycles) each in X, Y, and Z directions
Shock resistance	Destruction: 500 m/s <sup>2</sup> (approx. 50G) for 3 times each in X, Y, and Z directions
Soldering heat resistance	$260 \pm 5^{\circ}$ C when the portion between the tip of the terminals and the position 1.5 mm from the terminal base is dipped into the solder for $10 \pm 1$ seconds
Material	Case: Polybutylene phthalate (PBT), Cover: Polycarbonate (PC), Emitter/receiver: Polycarbonate (PC)

Note: The ambient illuminance is measured on the surface of the receiver.

# Engineering Data

## Sensing Position Characteristics (Typical)

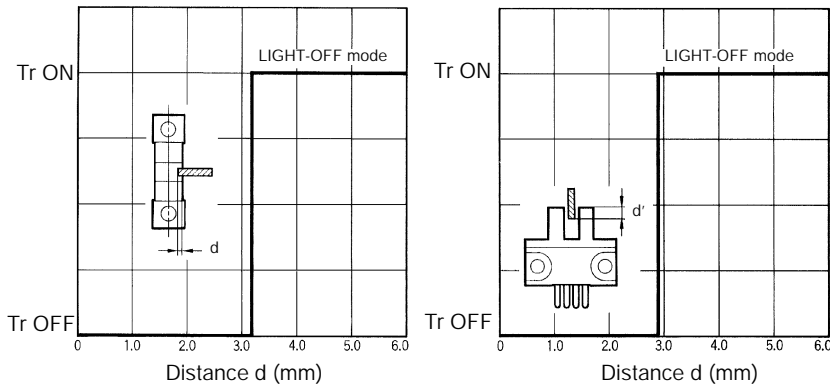

## Repeated Sensing Position Characteristics (Typical)

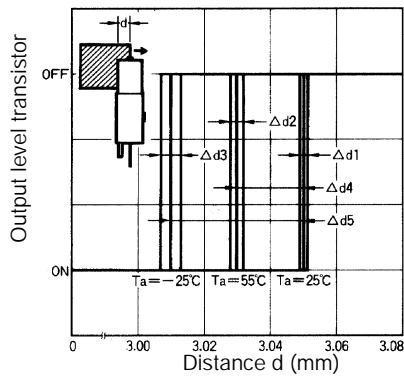

$V_{CC} = 12\text{ V}$   
 No. of repetitions: 20  
 $nd_1 = 0.002\text{ mm}$   
 $nd_2 = 0.004\text{ mm}$   
 $nd_3 = 0.005\text{ mm}$   
 $nd_4 = 0.02\text{ mm}$   
 $nd_5 = 0.04\text{ mm}$

# Operation

## Output Circuit Diagrams

EE-SX670, -SX671, -SX672, -SX673, -SX674

Light ON/OFF

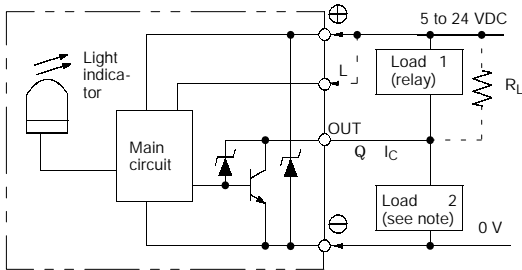

**Note:** When using on voltage output, always insert a resistor in RL and use load 2.

EE-SX470, -SX471, -SX472, -SX473, -SX474

Light ON

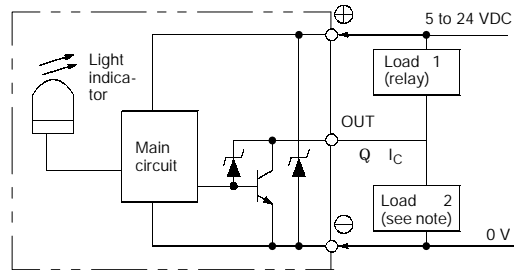

**Note:** Voltage output (when the sensor is connected to a transistor circuit).

EE-SX670A, -SX671A, -SX672A, -SX673A, -SX674A

Light ON/OFF

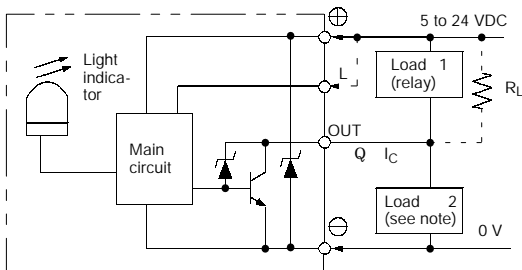

**Note:** When using on voltage output, always insert a resistor in RL and use load 2.

## Timing Chart

EE-SX670, -SX671, -SX672, -SX673, -SX674

Light ON

(When terminals L and ⊕ are short-circuited)

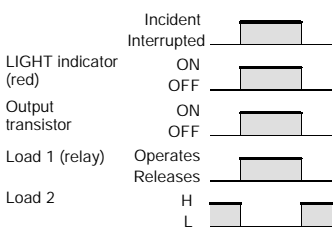

Light OFF

(When terminals L and ⊕ are open)

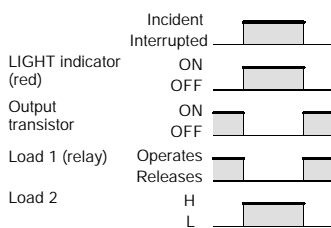

EE-SX470, -SX471, -SX472, -SX473, -SX474

Light ON

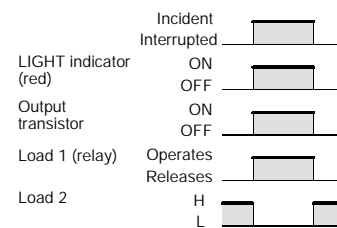

EE-SX670A, -SX671A, -SX672A, -SX673A, -SX674A

Light ON

(When terminals L and ⊕ are short-circuited)

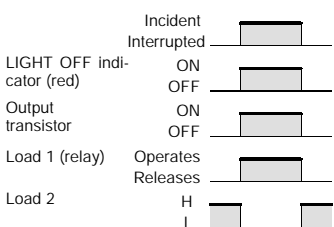

Light OFF

(When terminals L and ⊕ are open)

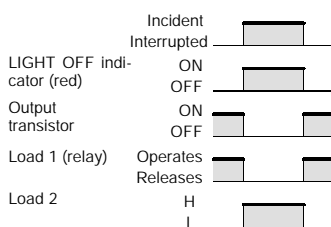

# Dimensions

Note: All units are in millimeters unless otherwise indicated.

EE-SX670  
EE-SX670A  
EE-SX470

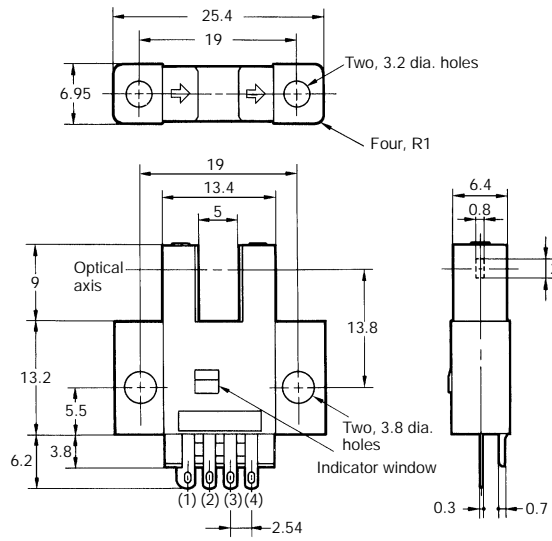
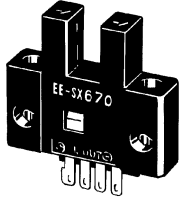

### Terminal Arrangement

(1)	⊕	Vcc
(2)	L	L (see note)
(3)	OUT	OUT PUT
(4)	⊖	GND (0 V)

Note: EE-SX470 is a vacant terminal

EE-SX671  
EE-SX671A  
EE-SX471

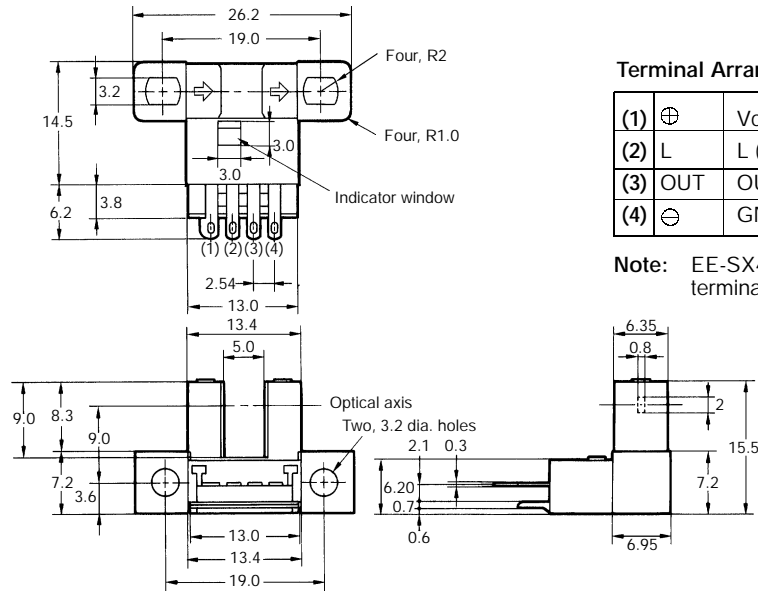
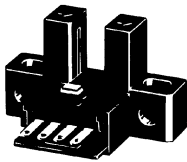

### Terminal Arrangement

(1)	⊕	Vcc
(2)	L	L (see note)
(3)	OUT	OUT PUT
(4)	⊖	GND (0 V)

Note: EE-SX471 is a vacant terminal

EE-SX672  
EE-SX672A  
EE-SX472

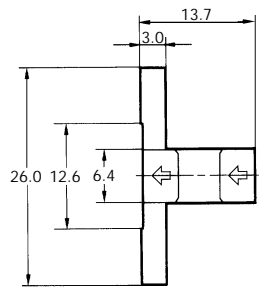
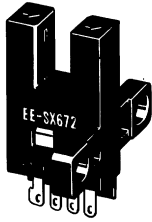

Terminal Arrangement

(1)	⊕	Vcc
(2)	L	L (see note)
(3)	OUT	OUT PUT
(4)	⊖	GND (0 V)

Note: EE-SX472 is a vacant terminal

EE-SX673  
EE-SX673A  
EE-SX473

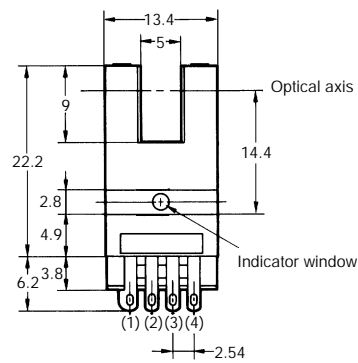
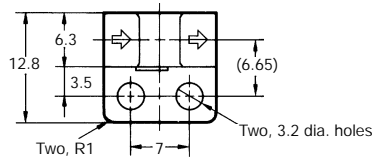
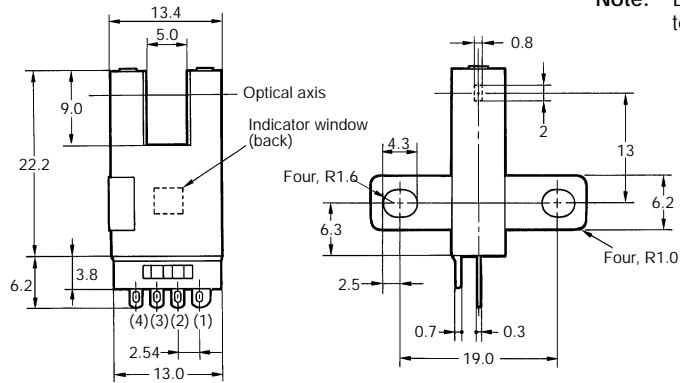
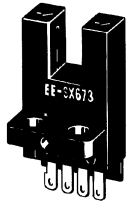

Terminal Arrangement

(1)	⊕	Vcc
(2)	L	L (see note)
(3)	OUT	OUT PUT
(4)	⊖	GND (0 V)

Note: EE-SX473 is a vacant terminal

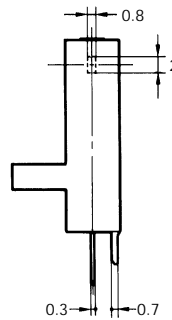

EE-SX674  
EE-SX674A  
EE-SX474

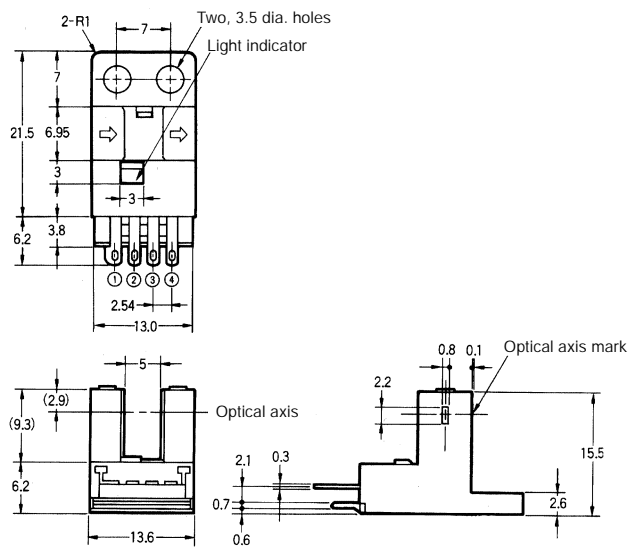
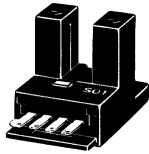

**Terminal Arrangement**

(1)	⊕	Vcc
(2)	L	L (see note)
(3)	OUT	OUT PUT
(4)	⊖	GND (0 V)

**Note:** EE-SX474 is a vacant terminal

**Applicable Connectors**

EE-1009, EE-1010, EE-1001-1, EE-1001, EE-1006, EE-1006A  
Refer to page 70 for details.

**Precautions**

Refer to page NO TAG, *Precautions* in *Technical Information*, for general precautions.

When direct soldering to the terminal, use the following guidelines.

**Soldering Conditions**

Item	Temperature	Permissible time	Remarks
Soldering Iron	350°C max.	3 sec max.	The portion between the base of the terminals and the position 1.5 mm from the terminal base must not be soldered.

The terminal base uses a polycarbonate resin, which could be deformed by excessive soldering heat.

**ALL DIMENSIONS SHOWN ARE IN MILLIMETERS.**  
To convert millimeters into inches, multiply by 0.03937. To convert grams into ounces, multiply by 0.03527.