

Reflective

- Photo-Darlington output.
- Sensing distance 4mm.
- The LED requires a forward current of only 5 mA.
- Red LED light source.
- Ideal for driving CMOS IC.
- Ideal for mounting directly to PCB tracking.

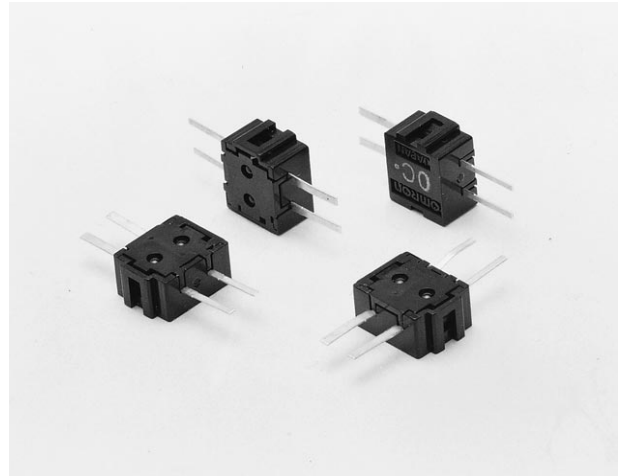

Dimensions

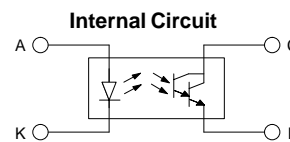
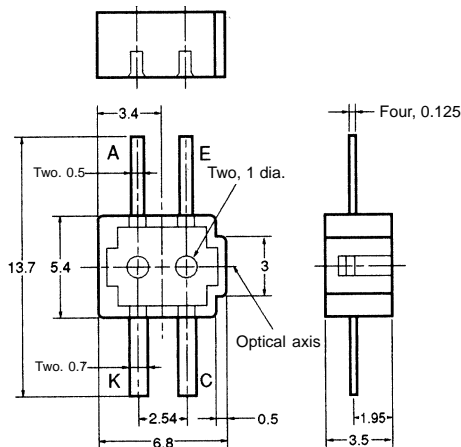

Terminal No.	Name
A	Anode
K	Cathode
C	Collector
E	Emitter

Unless otherwise specified, the tolerances are as shown below.

Dimensions	Tolerance
3 mm max.	±0.3
3 < mm ≤ 6	±0.375
6 < mm ≤ 10	±0.45
10 < mm ≤ 18	±0.55
18 < mm ≤ 30	±0.65

Specifications

■ Absolute Maximum Ratings (Ta = 25°C)

Item	Symbol	Rated value
Emitter	Forward current	I_F 15 mA (see note)
	Pulse forward current	I_{FP} ---
	Reverse voltage	V_R 4 V
Detector	Collector-Emitter voltage	V_{CEO} 24 V
	Emitter-Collector voltage	V_{ECO} ---
	Collector current	I_C 20 mA
	Collector dissipation	P_C 50 mW (see note)
Ambient temperature	Operating	T_{opr} -20°C to 60°C
	Storage	T_{stg} -20°C to 80°C
	Soldering	T_{sol} 260°C

Note: Refer to the temperature rating chart if the ambient temperature exceeds 25°C.

■ Electrical and Optical Characteristics (Ta = 25°C)

Item		Symbol	Value	Condition
Emitter	Forward voltage	V_F	2.0 V typ., 2.6 V max.	$I_F = 15$ mA
	Reverse current	I_R	0.01 μ A typ., 5 μ A max.	$V_R = 4$ V
	Peak emission wavelength	λ_P	700 nm typ.	$I_F = 10$ mA
Detector	Light current	I_L	0.3 μ A min., 8.0 μ A max.	$I_F = 5$ mA, $V_{CE} = 10$ V White paper with a reflection ratio of 90%, $d = 4$ mm (see note)
	Dark current	I_D	2 nA typ., 250 nA max.	$V_{CE} = 10$ V, 0 lx
	Leakage current	I_{LEAK}	---	---
	Collector–Emitter saturated voltage	$V_{CE}(\text{sat})$	---	---
	Peak spectral sensitivity wavelength	λ_P	750 nm typ.	$V_{CE} = 10$ V
Rising time		t_r	180 μ s typ.	$V_{CC} = 5$ V, $R_L = 100$ Ω , $I_L = 1$ mA
Falling time		t_f	60 μ s typ.	$V_{CC} = 5$ V, $R_L = 100$ Ω , $I_L = 1$ mA

Note: The letter “d” indicates the distance between the top surface of the sensor and the sensing object.

Engineering Data

Forward Current vs. Collector Dissipation Temperature Rating

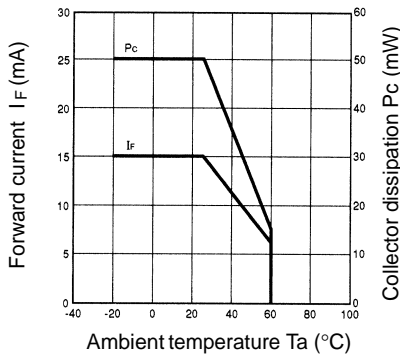

Light Current vs. Forward Current Characteristics (Typical)

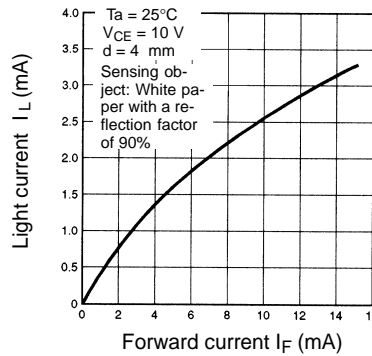

Light Current vs. Collector–Emitter Voltage Characteristics (Typical)

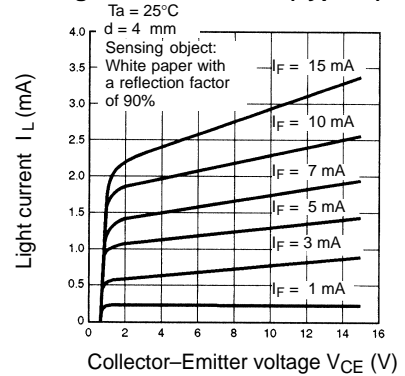

Relative Light Current vs. Ambient Temperature Characteristics (Typical)

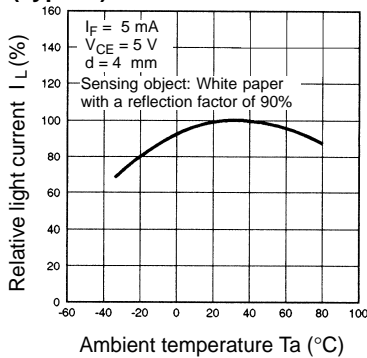

Dark Current vs. Ambient Temperature Characteristics (Typical)

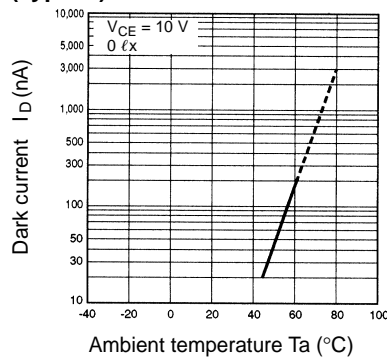

Response Time vs. Load Resistance Characteristics (Typical)

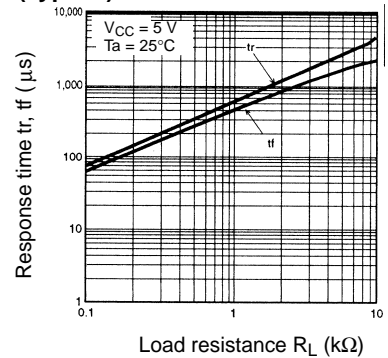

Sensing Distance Characteristics (Typical)

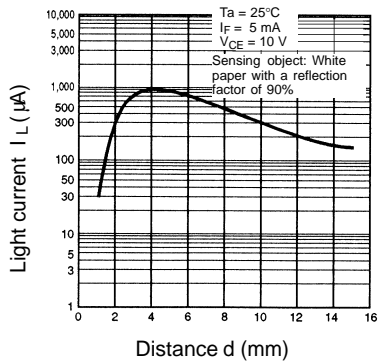

Sensing Position Characteristics (Typical)

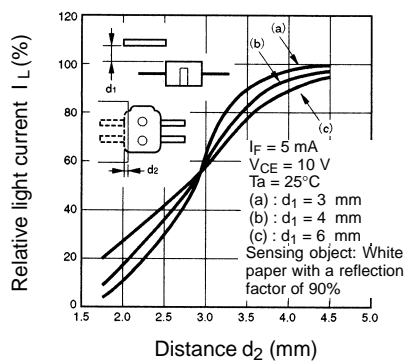

Sensing Angle Characteristics (Typical)

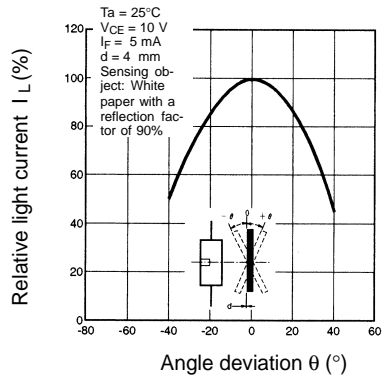

Response Time Measurement Circuit

