

Transmissive

- Photo-Darlington output.
- General-purpose model with a 3-mm-wide slot.
- PCB mounting type.
- Incorporating a visible red LED as emitter.
- Features a high (13mm) optical axis.
- Screw mounting tabs.

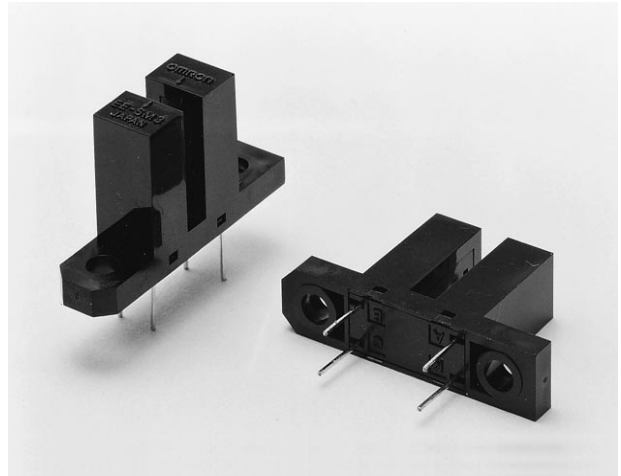

Dimensions

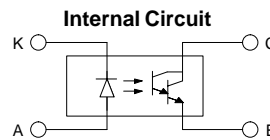
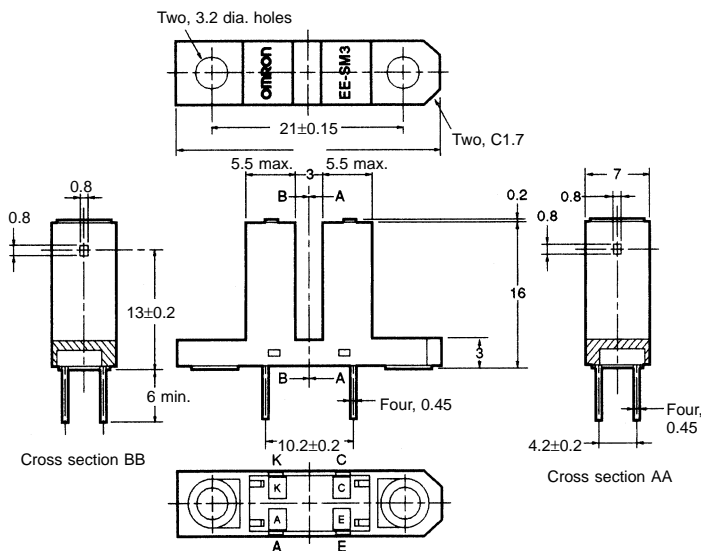

Terminal No.	Name
A	Anode
K	Cathode
C	Collector
E	Emitter

Unless otherwise specified, the tolerances are as shown below.

Dimensions	Tolerance
3 mm max.	±0.3
3 < mm ≤ 6	±0.375
6 < mm ≤ 10	±0.45
10 < mm ≤ 18	±0.55
18 < mm ≤ 30	±0.65

Specifications

■ Absolute Maximum Ratings (Ta = 25°C)

Item	Symbol	Rated value
Emitter	Forward current	I _F
	Pulse forward current	I _{FP}
	Reverse voltage	V _R
Detector	Collector-Emitter voltage	V _{CEO}
	Emitter-Collector voltage	V _{ECO}
	Collector current	I _C
	Collector dissipation	P _C
Ambient temperature	Operating	T _{opr}
	Storage	T _{stg}
	Soldering	T _{sol}

- Note:**
1. Refer to the temperature rating chart if the ambient temperature exceeds 25°C.
 2. The pulse width is 10 μs maximum with a frequency of 100 Hz.

■ Electrical and Optical Characteristics (Ta = 25°C)

Item		Symbol	Value	Condition
Emitter	Forward voltage	V_F	2.0 V typ., 2.6 V max.	$I_F = 15 \text{ mA}$
	Reverse current	I_R	0.01 μA typ., 5 μA max.	$V_R = 4 \text{ V}$
	Peak emission wavelength	λ_P	700 nm typ.	$I_F = 3 \text{ mA}$
Detector	Light current	I_L	1.5 mA min., 120 mA max.	$I_F = 3 \text{ mA}, V_{CE} = 10 \text{ V}$
	Dark current	I_D	2 nA typ., 250 nA max.	$V_{CE} = 10 \text{ V}, 0 \ell x$
	Leakage current	I_{LEAK}	---	---
	Collector-Emitter saturated voltage	$V_{CE}(\text{sat})$	0.9 V typ.	$I_F = 3 \text{ mA}, I_L = 0.5 \text{ mA}$
	Peak spectral sensitivity wavelength	λ_P	750 nm typ.	$V_{CE} = 10 \text{ V}$
Rising time		t_r	180 μs typ.	$V_{CC} = 5 \text{ V}, R_L = 100 \Omega, I_L = 10 \text{ mA}$
Falling time		t_f	60 μs typ.	$V_{CC} = 5 \text{ V}, R_L = 100 \Omega, I_L = 10 \text{ mA}$

Engineering Data

Forward Current vs. Collector Dissipation Temperature Rating

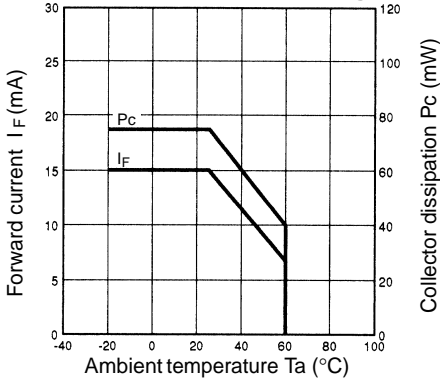

Forward Current vs. Forward Voltage Characteristics (Typical)

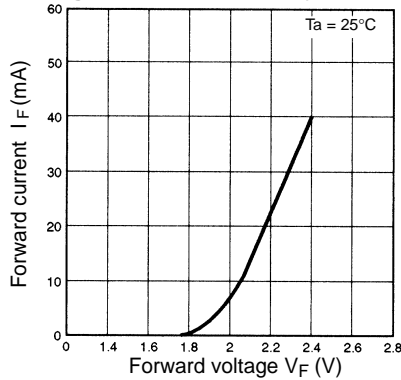

Light Current vs. Forward Current Characteristics (Typical)

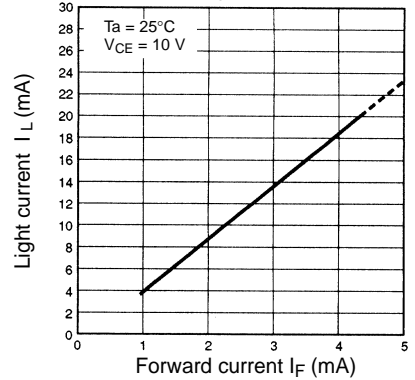

Light Current vs. Collector-Emitter Voltage Characteristics (Typical)

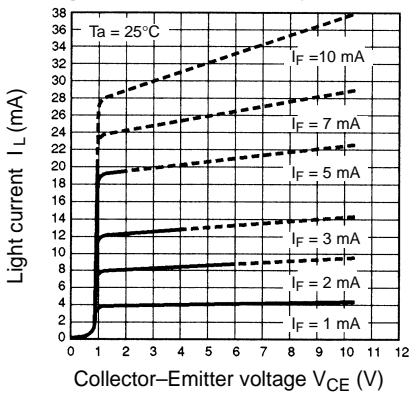

Relative Light Current vs. Ambient Temperature Characteristics (Typical)

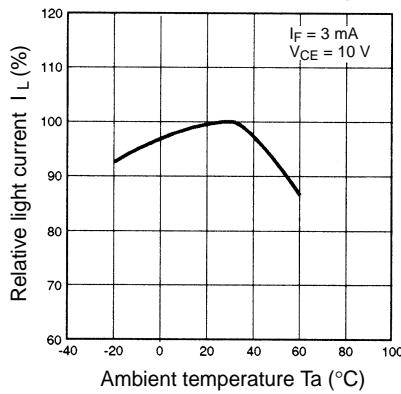

Dark Current vs. Ambient Temperature Characteristics (Typical)

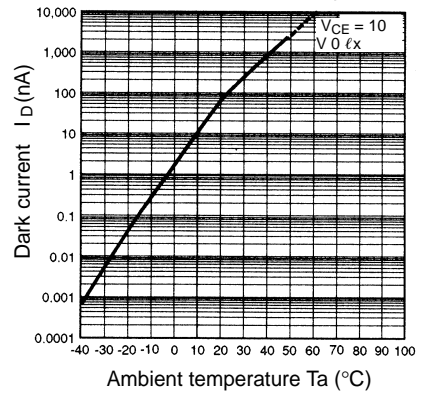

Response Time vs. Load Resistance Characteristics (Typical)

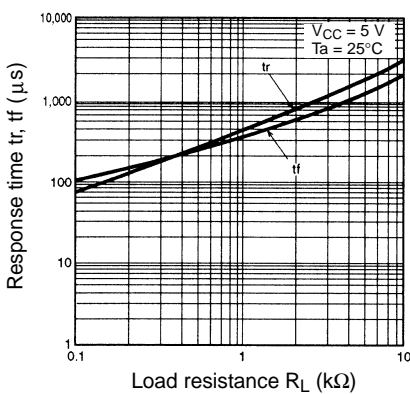

Sensing Position Characteristics (Typical)

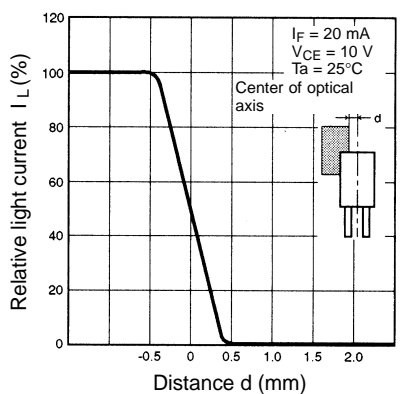

Response Time Measurement Circuit

