

**CS1 Series, C200HX/HG/HE, C200HS, C200H
C200H-MC221**

Motion Control Unit

Specification Sheets

OMRON

CS1 Series, C200HX/HG/HE, C200HS, C200H Motion Control Unit

C200H-MC221

2-axis Motion Control with Multitasking G Language

■ The C200H-MC221 is a 2-axis Motion Control Unit for the CS1-series, C200HX/HG/HE, C200HS, and C200H PCs. With its built-in G-language programming, it can be used for advanced motion control, and its multitasking capability allows operations to be performed independently for each axis. The following two modes can be used for motion control:

1. Motion control by G language programming in the MC Unit (Automatic Mode)
2. Motion control by instructions from the PC interface area in the CPU Unit or by manual commands from the Teaching Box (Manual Mode)

The MC Unit has been developed for use in simple positioning applications using servomotors. Applicable machines are as follows:

- Conveyor Systems: X/Y tables, palletizers/depalletizers, loaders/unloaders, etc.
- Assembling Systems: Simple robots (including orthogonal robots), simple automated assembling machines (such as coil winding, polishing, hole punching), etc.

Note: The MC Unit is not designed to perform linear interpolation, circular interpolation, or helical circular interpolation with horizontal articulated robots or cylindrical robots, because it does not support coordinate conversions. The MC Unit can, however, perform PTP control with these robots.

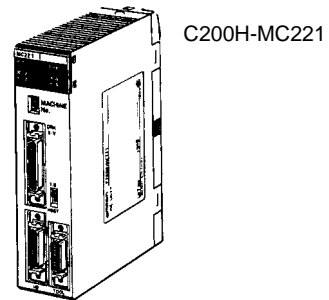

■ System Configuration

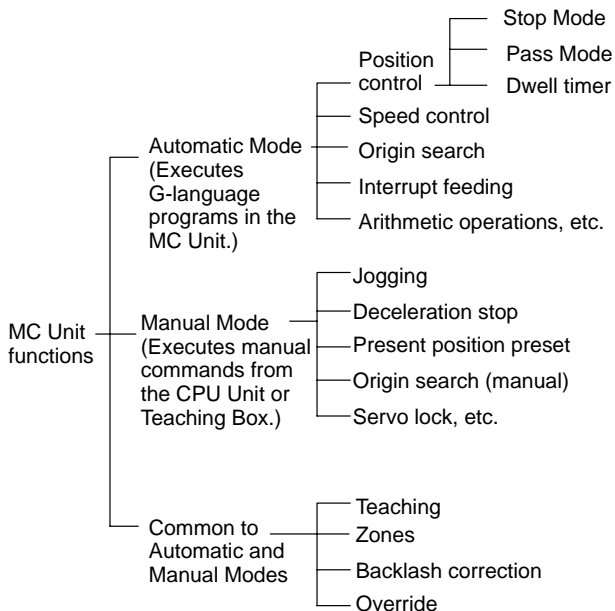
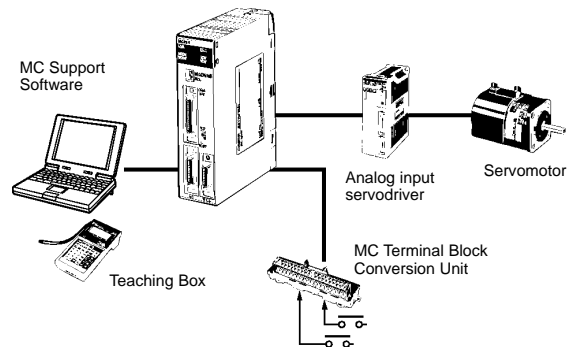

Automatic Mode

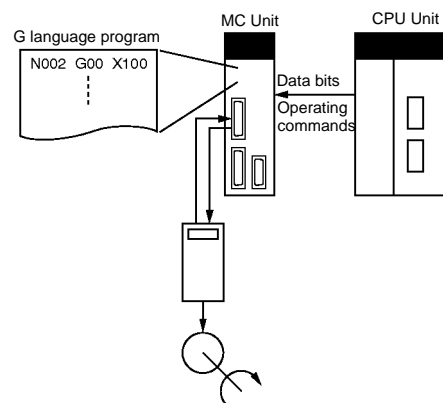

Manual Mode

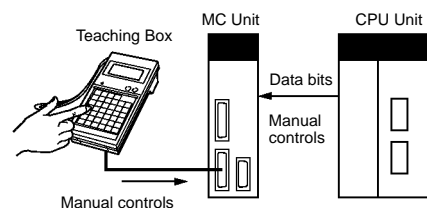

“Programmable Controller” is abbreviated as “PC” in these *Specification Sheets*.

■ Features

Multitasking G Language to Reduce CPU Unit Programming

The MC Unit is provided with a multitasking G language, an ideal language for motion control. Up to 100 programs can be registered.

- Multiaxis control programs can be easily created.
- Position control can be performed by specifying program numbers using the PC interface area and executing operation commands, reducing the workload on the CPU Unit's ladder program.
- Axis configuration can be set, such as controlling X-Y robot operations or controlling operations separately for each axis.

Up to 16 Axes Can be Controlled for Each CPU Unit

Up to 8 MC Units can be mounted to a CPU Unit, so up to 16 axes can be controlled.

High-speed Response to Start Commands from CPU Unit

The response time from when a start command is received from the CPU Unit until the command voltage is output from the MC Unit is 12 ms.

Operation Can be Started or Stopped by General-purpose Inputs

The MC Unit is provided with general-purpose inputs, so operation can be started or stopped without needing intervention by the CPU Unit.

- General-purpose inputs can be used as jog start signals, external device interlock signals, restart signals, and other signals.

- The MC Unit can perform high-speed-response positioning by itself.

Interrupt Feeding Function Provided as Standard

The MC Unit can perform high-speed positioning for feeding operations (such as for feeders) by external sensors.

Compatible with Absolute Encoders

This MC Unit is compatible with OMNUC U-series and other Servomotors with absolute encoders. It no longer requires origin searches, and allows quick start and reset at system start-up or power-down. The MC Unit can also handle a mixture of absolute and incremental encoders.

250-kp/s Encoder Response Frequency

The maximum feedback encoder response frequency is 250 kp/s, so the MC Unit can be used with high-speed and high-precision servomotors.

Data Creation Using Teaching Box

In addition to entering numbers in the Position Data Edit Window of the MC Support Software, it is possible to create position data by using the Teaching Box to teach positions while actually moving the machinery.

Operate with MPG

Positioning and simple sync operations can be performed using an MPG (manual pulse generator).

Special Cable for Connecting Servodrivers

■ Models

Applicable PCs	Unit classification	Number of controlled axes	Controlled servodriver	Model
CS1, C200HX/HG/HE C200HS, C200H	C200H Special I/O Unit	2 axes	Analog input servodriver	C200H-MC221

MC Unit Support Software (Sold Separately)

Name	Computer	Specifications	Model
MC Support Software	IBM PC/AT or compatible	Editing system parameters, editing position data, creating MC programs (G language), transferring data to MC Unit, monitoring MC Unit, saving data in flash memory, and printing	CV500-ZN3AT1-E
RS-422 Cable (connects to peripheral connector on Unit front panel)	IBM PC/AT or compatible	Cable: 3.3 m (connector on MC Unit end: half-pitch 20-pin, connector on computer end: D-sub 25-pin) 25-to-9-pin conversion connector manufactured by Sanwa Supply	CV500-CIF01 D09-9F25F (Sanwa Supply)

■ Specifications

Item	Specifications
Model number	C200H-MC221
Applicable PC	CS1-series, C200HX/HG/HE, C200HS, C200H
Unit classification	C200H Special I/O Unit
Racks on which MC Unit can be mounted	CPU Rack, C200H Expansion I/O Rack, CS1 Expansion Rack, SYSMAC BUS Remote I/O Slave Rack
Maximum number of MC Units that can be mounted	8 Units (16 axes) or 5 Units (10 axes) depending on the PC model. (For details, refer to <i>Connectable CPU Unit Models</i> .)
Unit numbers	0 to 8 and A to E, or 0 to 8 depending on the PC model. (For details, refer to <i>Connectable CPU Unit Models</i> .)

Model number		C200H-MC221
Method for data transfer with CPU Unit	Words allocated to Special I/O Units in CIO Area	20 words/Unit (uses 2 unit numbers.) CPU Unit to MC Unit: Program numbers, cycle start (MC program operation command), origin search command, automatic/manual mode switching, etc. MC Unit to CPU Unit: Status: Positioning completed, zones, busy flag, etc. Monitor data: Present position, error codes, M codes, etc.
	Words allocated to Special I/O Units in DM Area	2 words used out of 100 words allocated Expansion Data words are specified in initial settings.
	Words in Expansion Data Area (DM or EM Area)	23 words per Unit CPU Unit to MC Unit: Data transfer area specifications, present position preset values, etc. MC Unit to CPU Unit: System error codes, task error codes, effective program numbers, etc.
Controlled servodrivers		Analog input servodrivers (Example: OMRON OMNUC H, M, or U Series)
Encoder interface		Line receiver input; maximum response frequency: 250 kp/s (before multiplication) Pulse ratio: 4 (fixed) Note: The applicable absolute encoder is the OMRON OMNUC U Series.
Built-in program language		G language (Started by receiving a start command from the CPU Unit ladder diagram program.)
Control	Control method	Speed reference voltage output-type semi-closed loop system, using incremental and absolute encoder inputs (automatic trapezoidal or S-curve acceleration/deceleration method)
	Number of controlled axes	2 axes max.
	Number of simultaneously controlled axes	2 axes max.
	PTP (independent) control	Multitasking can be used to execute independent operating modes and programs for each axis.
Automatic/Manual Mode (for each task)		Automatic Mode: Mode for executing MC program created in G language. Manual Mode: Mode for executing manual commands from CPU Unit (PC interface area) or Teaching Box. Note: The Automatic and Manual Modes are switched according to the PC interface area of the CPU Unit. There are a total of 10 Manual Mode commands, including origin search, reference origin return, jogging, and present position preset. The operation command (cycle start) is started in Automatic Mode using the PC interface area of the CPU Unit.
Positioning operations	Independent	Independent operations for a maximum of two axes
	Linear interpolation	Linear interpolation for a maximum of two axes
	Circular interpolation	Circular interpolation for a maximum of two axes on a plane.
	Interrupt feeding	Operations for each axis
Position specification method		Operating positions can be specified in MC programs by using one of the following three methods. Direct Specification of Coordinate Values Example: When G00 X100 is specified with absolute specification, the X axis moves to a position of 100. Address Specification of Position Data Example: When G00 XA0000 is specified, the axis moves to the position set as position data address 0000. Indirect Register Specification Example: When G00 X(E00) is specified, the X axis moves to the position set as the position data address in the E00 indirect register.
Control unit	Minimum setting unit	1, 0.1, 0.01, 0.001, 0.0001
	Units	mm, inch, degree, pulse (There is no unit conversion function.)
Maximum command value		-39,999,999 to +39,999,999
Acceleration/deceleration curve		Trapezoidal or S-curve (Can be selected for each axis.)
Acceleration/deceleration time		Individual acceleration/deceleration settings possible: 0 to 9,998 ms (2-ms increments)
Speed reference		Speed control for a maximum of two axes. When the unit is pulses, the setting range is from 1 p/s to 1,000 kp/s (after multiplication by 4).
Feed rate (PTP operation) specification method		Can be set for each axis. Feed rate = High speed × Override value/100 Real-time speed can be changed by altering the override value.

Model number		C200H-MC221	
External I/O	Input	Individual axis control	The following signals are each provided for two axes: CCW limit inputs CW limit inputs Origin proximity inputs Emergency stop inputs
		Servodriver relationships	The following signal is provided for two axes: Driver alarm signal
		Encoder	Line receiver inputs For two axes 250 kp/s max. before multiplication Fixed at $\times 4$ Note: When using a manual pulse generator (MPG), connect it to the Y-axis encoder input terminal. (X-axis + MPG)
		General-purpose inputs	2 points (for external start commands, etc.)
	Output	Servodriver relationships	The following signals are each provided for two axes: Speed command voltage output (± 10 V) Operation command output SEN signal (for absolute encoder) Driver alarm reset signal
	Peripheral device	1 serial channel for Teaching Box or MC Support Software (switchable using the slide switch on the front panel) Teaching Box: 9,600 bits/s for RS-422 MS Support Software: 9,600 bits/s for RS-422 and RS-232C	
Feed operations	Maximum rapid feed rate	Maximum feed rate for PTP operation 36.86 m/min under the following conditions: Encoder resolution: 2,048 p/r Motor speed: 4,500 r/m Control unit: 0.001 mm/pulse	
	Maximum interpolation feed rate	Maximum feed rate for interpolation operations 36.86 m/min under the same conditions as above	
	Rapid feed override	0% to 100.0% (Setting unit: 0.1%)	
	Interpolation feed override	0% to 199.9% (Setting unit: 0.1%)	
	Jog feed override	0% to 100.0% (Setting unit: 0.1%)	
Axis control	Zone settings	Up to 8 zones/axis can be set.	
	Backlash correction	Backlash for mechanical system Can be set from 0 to 999 pulses.	
	In-position zone	Number of accumulated pulses for determining the positioning completed status Can be set from 0 to 999 pulses.	
	Position loop gain	Servo system response adjustment gain 5 to 250 (1/s)	
	Position loop feed-forward gain	Servo system response adjustment gain 0% to 100%	
Task program management	Number of tasks	2 max. (program execution units)	
	Number of programs	When 1 task is used: 100 max. When 2 tasks are used: 50 max./task	
	Program capacity	When 1 task is used: 800 blocks max. When 2 tasks are used: 400 blocks max./task	
	Position data capacity	2,000 positions max. (when only one axis is used) (A0000 to A1999)	
	Number of registers	32 (Mainly used for specifying position data numbers.) (E00 to E31)	
	Subroutine nesting	5 levels max.	
Auxiliary function	M code	000 to 999	
Saving program data	MC Unit	MC programs, system parameters, and position data can be stored in the flash memory in the MC Unit.	
	External peripheral devices	MC Support Software can be used to save data to a floppy disk or the hard disk at the personal computer.	
Self-diagnostic function		Memory corruption is detected.	
Error detection functions		Error counter warning, error counter over, absolute encoder error detection, CPU errors, communications errors (Teaching Box), flash memory error, EEPROM error, software limit over error, phase-Z error, overtravel, emergency stop, unit number error, driver alarm detection, driver reverse wiring detection, CPU Unit error detection	

Model number	C200H-MC221
Settings	The following switches are located on the front panel. Rotary switch: Unit number setting (0 to 8, A to E) Slide switch: Peripheral selection switch (used for determining whether to connect the peripheral connector to Teaching Box or MC Support Software) The following switch is located on the rear panel. DIP switch: Absolute encoder default setting function, software switch enabled/disabled, Teaching Box Japanese/English mode switching
Indicators	6 LED indicators: Running, error, motor rotation direction (CCW/CW)
Connectors on front panel	Servodriver connector, I/O connector, peripheral connector (one each)
Internal current consumption (supplied from Power Supply Unit)	650 mA or less at 5 VDC (with Teaching Box connected: 850 mA or less) 200 mA or less at 24 VDC
Dimensions	130.0 × 34.5 × 100.5 mm (H × W × D) Single-slot size Note: The height including the Backplane is 200 to 240 mm when the attached connector and the recommended cable are used.
Weight (Connectors excluded)	500 g max.
Safety standards	Conforms to UL (Class 2), CSA (Class 2), and EC directives (EMC directive, low-voltage directive).
Standard accessories	10126-3000VE snap-on connector for Servodrivers and 10326-42F0-008 connector cover (manufactured by Sumitomo 3M): 1 set Peripheral connector (10120-3000VE 20-pin connector and 10320-42F0-008 connector cover manufactured by Sumitomo 3M): 1 set
Cat No.	Introduction: W314, Details: W315 (suffixes omitted)

■ Options (Sold Separately)

Name	Specifications	Model	
MC Terminal Block Conversion Unit	For easier wiring of I/O connectors	XW2B-20J6-6	
MC Terminal Block Conversion Unit Cable	For connecting the I/O connectors on the front panel of the Unit	XW2Z-100J-F1	
Snap-on connector for Servodriver connector on Unit front panel (1 set provided as standard on this Unit)	Soldered connector	10126-3000VE (Sumitomo 3M)	
	Connector cover	10326-42F0-008 (Sumitomo 3M)	
RS-232C cable and connector for MC Support Software	Recommended cable	CO-DS-IREVV-SX-10P × 0.18 mm ² (Hitachi Cable)	
	Peripheral connector on Unit front panel (1 set provided as standard on this Unit)	Soldered connector	10120-3000VE (Sumitomo 3M)
		Connector cover	10320-42F0-008 (Sumitomo 3M)
Teaching Box	Jogging, origin search, present value monitoring, and other operations by means of manual commands Teaching (taking present values into position data)	CVM1-PRO01-E	
Teaching Box Connecting Cable	Cable length: 2 m	CV500-CN224	
	Cable length: 4 m	CV500-CN424	
	Cable length: 6 m	CV500-CN624	
ROM Cassette	---	CVM1-MP702	

■ Applicable CPU Units

PC	CPU Unit model	Total number of MCUs that can be mounted on CPU Units, Expansion I/O Racks, and SYSMAC BUS Remote I/O Slave Racks (see note)	Unit location restrictions
CS1-series	CS1H-CPU□□ CS1G-CPU□□	8 (unit numbers 0 to 8 and A to E)	None
C200HX/HG/HE	C200HE-CPU11/32/42 (-ZE) C200HG-CPU33/43 (-ZE) C200HX-CPU34/44 (-ZE)	5 (unit numbers 0 to 8)	None
	C200HG-CPU53/63 (-ZE) C200HX-CPU54/64 (-ZE) C200HX-CPU65-ZE/85-ZE	8 (unit numbers 0 to 8 and A to E)	None
C200HS	C200HS-CPU01(-□)/21(-□)/31/03/23/33	5 (unit numbers 0 to 8)	None
C200H	C200H-CPU01/02/03/11/21/22/23/31	5 (unit numbers 0 to 8)	Cannot be mounted to two rightmost slots on CPU Rack.

Note: Restrictions on SYSMAC BUS Remote I/O Slave Racks

The maximum number of C200H Special I/O Units that can be mounted on a SYSMAC BUS Remote I/O Slave Unit differs according to

the Unit type as shown below. C200H Special I/O Units can be divided into the following four groups according to the maximum number of Units that can be mounted.

Group	A	B	C	D
Units	ASCII Unit, High-speed Counter Unit, Position Control Unit (NC111/112/113/213), Analog I/O Unit, ID Sensor Unit, Fuzzy Logic Unit	Multipoint I/O Unit, Temperature Control Unit, PID Control Unit, Heating/Cooling Control Unit, Cam Positioner Unit	Temperature Sensor Unit, Voice Unit	Position Control Unit (NC211/413), Motion Control Unit
Maximum number of Units that can be mounted in each group under one Master	4 Units	8 Units	6 Units	2 Units
Maximum number of Units that can be mounted in all groups	$3A + B + 2C + 6D \leq 12$, and $A + B + C + D \leq 8$			

■ MC Unit Functions and Execution Methods

The MC Unit functions can be executed using either of the following three methods.

1. Using MC programs (G language)
2. Specifying functions from the CPU Unit to the MC Unit through the PC interface area
3. Specifying system parameters by using MC Support Software, IOWR instructions, or I/O transfer bits

Function	Execution methods (Modes in parentheses: Valid modes)		
	MC program (G language)	PC interface area	System parameters
Positioning with linear interpolation	(G01) (Automatic Mode)	---	---
Positioning with circular interpolation	(G02/03) (Automatic Mode)	---	---
Speed control	(G30) (Automatic Mode)	---	---
Interrupt feeding	(G31) (Automatic Mode)	---	---
Switching to Pass Mode	(G10) (Automatic Mode)	---	---
Switching to Stop Mode	(G11) (Automatic Mode)	---	---
Dwell timer setting/execution	(G04) (Automatic Mode)	---	---
In-position setting	---	---	(Automatic/Manual Mode)
Workpiece origin return	(G27) (Automatic Mode)	---	---
Position loop gain setting	---	---	(Automatic/Manual Mode)
Cycle start	---	(Automatic Mode)	---
Single block	---	(Automatic Mode)	---
Pause	---	(Automatic Mode)	---
Forced block end	---	(Automatic Mode)	---
Origin search	(G28) (Automatic Mode)	(Manual Mode)	---
Reference origin return	(G26) (Automatic Mode)	(Manual Mode)	---
Override setting	---	(Automatic/Manual Mode)	---
Error counter reset	---	(Automatic/Manual Mode)	---
Driver alarm reset	---	(Automatic/Manual Mode)	---
M code reset	---	(Automatic Mode)	---
Teaching	---	(Automatic/Manual Mode)	---
Jogging	---	(Manual Mode)	---
Deceleration stop	---	(Manual Mode)	---
Forced origin	---	(Manual Mode)	---
Absolute encoder origin setting	---	(Manual Mode)	---
Servo-lock	---	(Manual Mode)	---
Servo-unlock	---	(Manual Mode)	---
Trapezoidal/S-curve specification	---	---	(Automatic/Manual Mode)
Zone settings	---	---	(Automatic/Manual Mode)
Backlash correction setting	---	---	(Automatic/Manual Mode)
Origin deceleration method	---	---	(Automatic/Manual Mode)

■ G Language

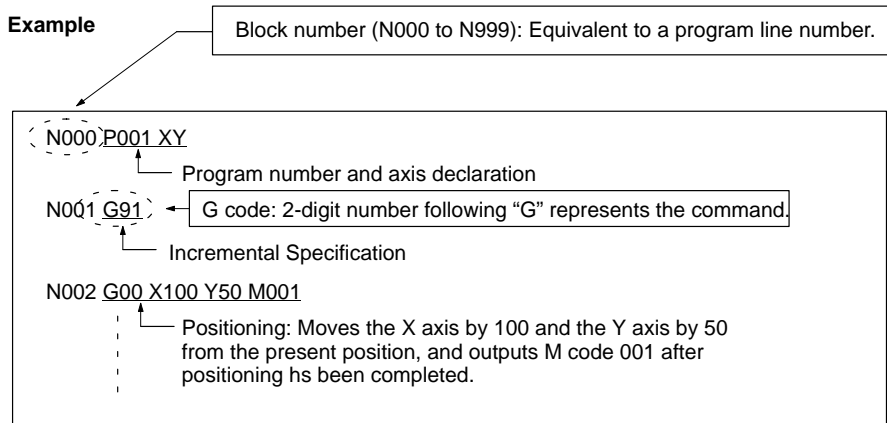

Code	Name	Function
G00	Positioning	Performs positioning according to maximum rapid feed rate × override (%). (PTP control)
G01	Linear Interpolation	Performs linear interpolation on 1, 2, 3, or 4 axes (1 or 2 axes for MC221). The specified axes move simultaneously. The feed rate can be specified.
G02	Circular Interpolation (Clockwise)	Performs 2-axis circular interpolation in the clockwise direction at the specified interpolation feed rate.
G03	Circular Interpolation (Counterclockwise)	Performs 2-axis circular interpolation in the counterclockwise direction at the specified interpolation feed rate.
G04	Dwell Timer	Waits for the specified length of time.
G10	Pass Mode	Performs operations one-by-one in sequence without waiting for deceleration to stop.
G11	Stop Mode	Performs the next operation after completing positioning.
G17	Circular Plane Specification (X-Y)	Sets the X-Y plane as the plane for circular interpolation.
G26	Reference Origin Return	Moves to the reference origin.
G27	Workpiece Origin Return	Moves to the workpiece origin.
G28	Origin Search	Performs an origin search on the specified axis.
G29	Origin UNDEFINED	Sets the origin to an undefined state.
G30	SPEED CONTROL	Feeds up to 2 axes simultaneously at the controlled feed rate.
G31	INTERRUPT FEEDING	Performs an interrupt feeding operation.
G50	Select Reference Coordinate System	Specifies the reference coordinate system.
G51	Select Workpiece Coordinate System	Specifies the workpiece coordinate system.
G53	Change Workpiece Origin Offset	Changes the origin of the workpiece coordinate system.
G54	Change Reference Coordinate System PV	Changes the present value in the reference coordinate system.
G60	Arithmetic Operations	Performs arithmetic operations on numerical values, position data, and registers.
G63	Substitution	Substitutes numerical values, position data, or registers into other position data or registers.
G69	Change Parameter	Changes the acceleration/deceleration time.
G70	Unconditional Jump	Unconditionally jumps to the specified block.
G71	Conditional Jump	Jumps to the specified block when the condition is met.
G72	Subroutine Jump	Calls the specified subroutine.
G73	Subroutine End	Ends the subroutine.
G74	Optional End	Ends the block currently being executed when the specified optional input is ON.
G75	Optional Skip	Skips the block after this command when the specified optional input is ON.
G76	Optional Program Stop	Pauses the program when the specified optional input is ON.
G79	Program End	Ends the main program.
G90	Absolute Specification	Positions with absolute coordinates when performing axis operations.
G91	Incremental Specification	Positions with relative coordinates when performing axis operations.

■ Auxiliary Codes

Code	Name	Function
M	M code	Outputs an M code.

■ System Configuration
Control System

Semi-closed Loop System

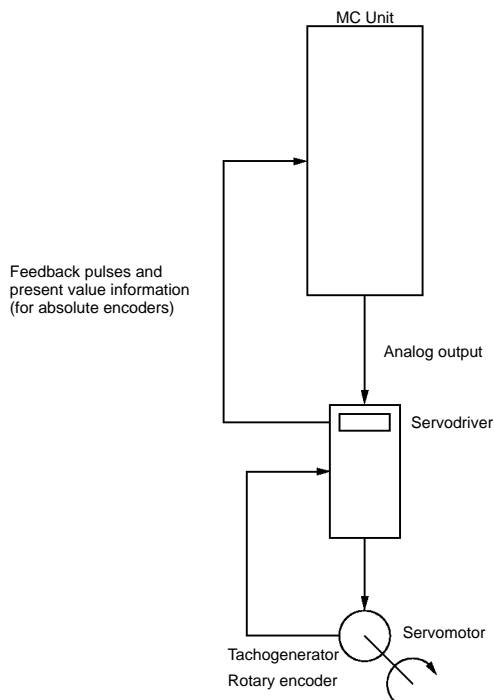

Connected Configuration

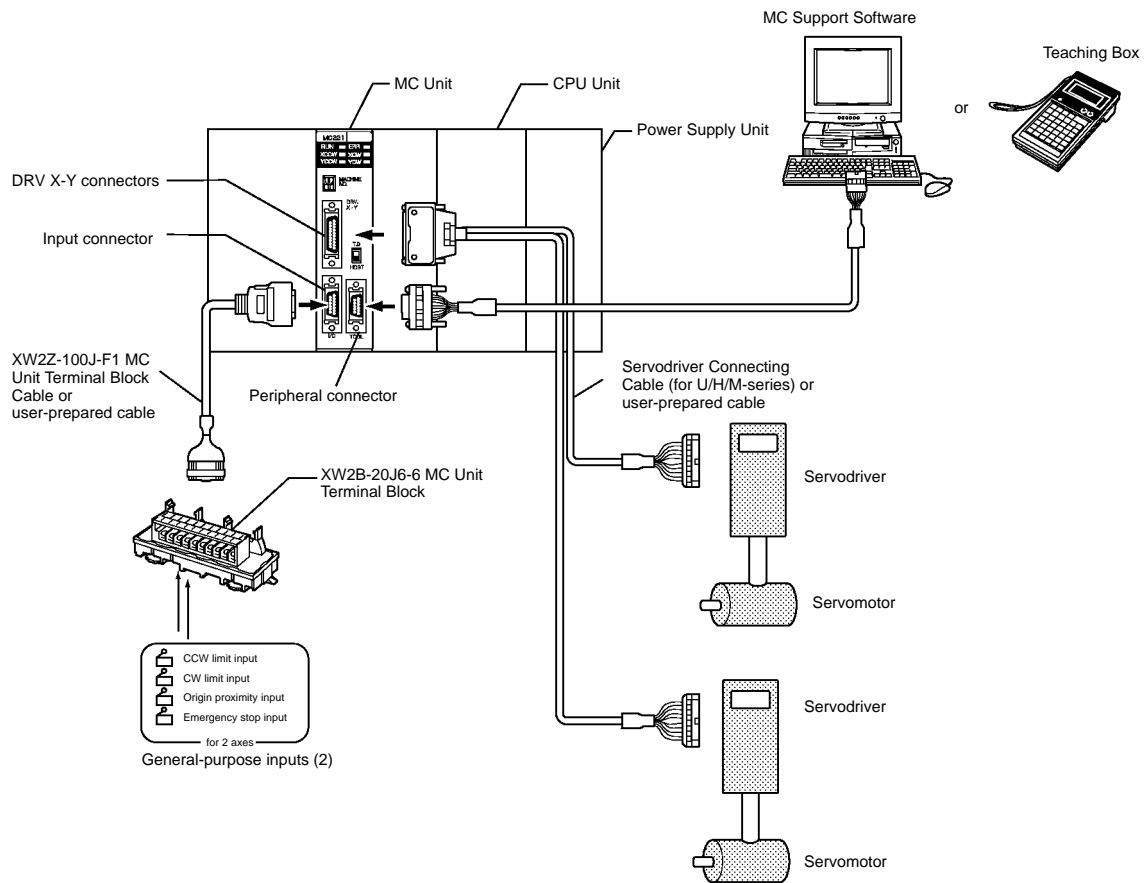

■ Exchanging Data

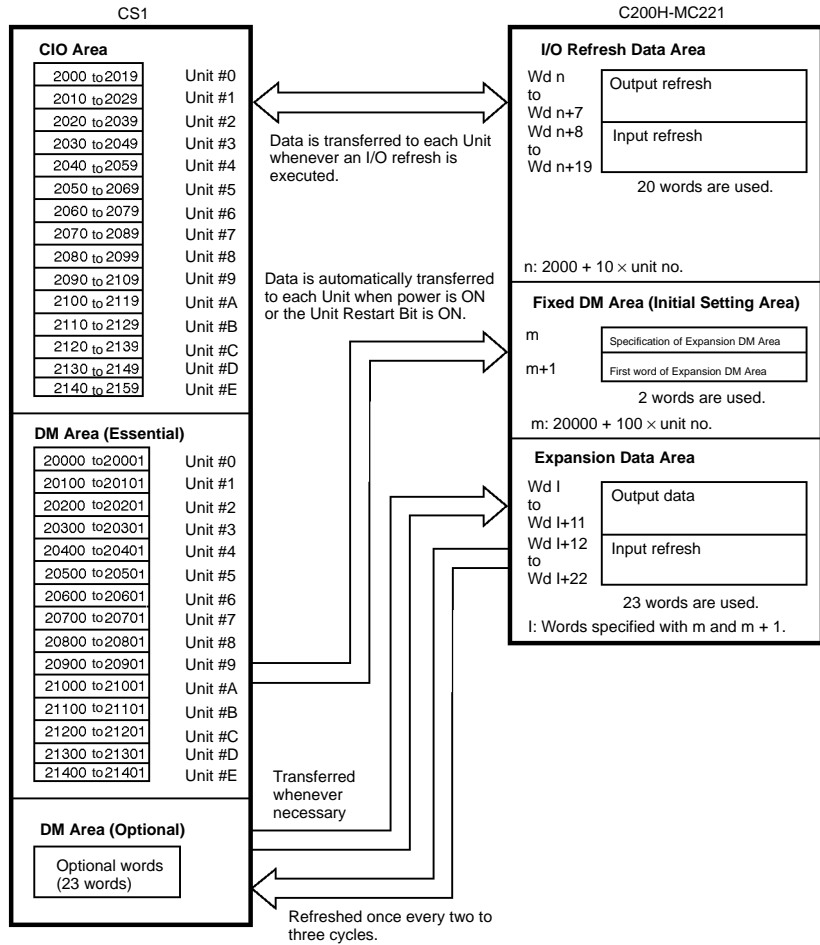

	Word	Description	X-axis control bit	
PC to MC	n	Task 1 program no.	00	Deceleration stop
	n+1	Task 1 system control bit	01	Origin search
	n+2	Task 2 program no.	02	Reference origin return
	n+3	Task 2 system control bit	03	Jogging
	n+4	X-axis override	04	Not used
	n+5	X-axis control bit	05	Present position preset
	n+6	Y-axis override	06	Reserved
MC to PC	n+7	Y-axis control bit	07	Reserved
	n+8	Error data and system status	08	MPG enabled
	n+9	Error code	09	Servo lock
	n+10	Task 1 M code	10	Servo free
	n+11	Task 1 status	11	Driver alarm reset
	n+12	Task 2 M code	12	Override set
	n+13	Task 2 status	13	Jogging direction
	n+14	X-axis present position	14	MPG multiplication factor 1
	n+15		15	MPG multiplication factor 2
	n+16	X-axis status (zone, etc.)		
	n+17	Y-axis present position		
	n+18			
	n+19	Y-axis status (zone, etc.)		

■ Component Names

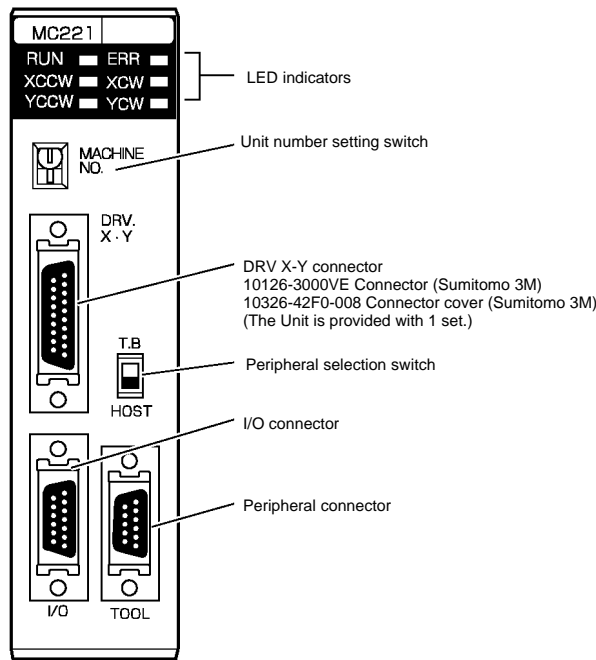

Indicators

Indicator	Color	Status	Meaning
RUN	Green	ON	Initialization has been completed normally. (Connected to the CPU Unit normally.)
		OFF	An error has occurred in the MC Unit or the CPU Unit.
ERR	Red	ON	An error has occurred in the MC Unit.
		OFF	The MC Unit is operating normally.
XCCW YCCW	Orange	ON	The motor is rotating counterclockwise.
		OFF	The motor is rotating clockwise or stopped.
XCW YCW	Orange	ON	The motor is rotating clockwise.
		OFF	The motor is rotating counterclockwise or stopped.

■ External I/O Connections: Input Connector

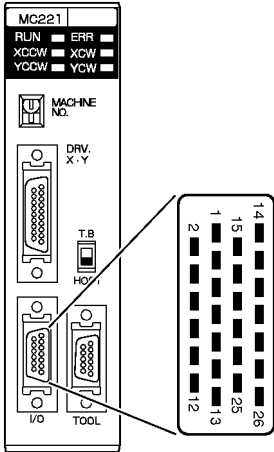

Pin	Symbol	Terminal on MC Unit terminal block	Name	Function
1	+24 V	10	24-VDC input	Connects to the + terminal of the 24-VDC external power supply.
2	XCWL (NC)	11	X-axis CW limit input	Limits movement of the X axis in the CW direction.
3	YCWL (NC)	16	Y-axis CW limit input	Limits movement of the Y axis in the CW direction.
4	XCCWL (NC)	12	X-axis CCW limit input	Limits movement of the X axis in the CCW direction.
5	YCCWL (NC)	17	Y-axis CCW limit input	Limits movement of the Y axis in the CCW direction.
6	XSTOP (NC)	14	X-axis emergency stop input	Disables the X-axis run output and stops it.
7	YSTOP (NC)	8	Y-axis emergency stop input	Disables the Y-axis run output and stops it.
8	IN1 (NO)	4	General input 1	General input 1
9	IN2 (NO)	9	General input 2	General input 2
10	XORG (NC, NO)	13	X-axis origin proximity input	Used for the X-axis origin search.
11	YORG (NC, NO)	18	Y-axis origin proximity input	Used for the Y-axis origin search.
14	DC GND	0	24-VDC input ground	Connects to the – terminal (0 V) of the 24-VDC external power supply.

“NC” stands for normally closed and “NO” stands for normally open.

■ External Connection Diagram Using the MC Unit Input Connector

Example: X-axis Wiring

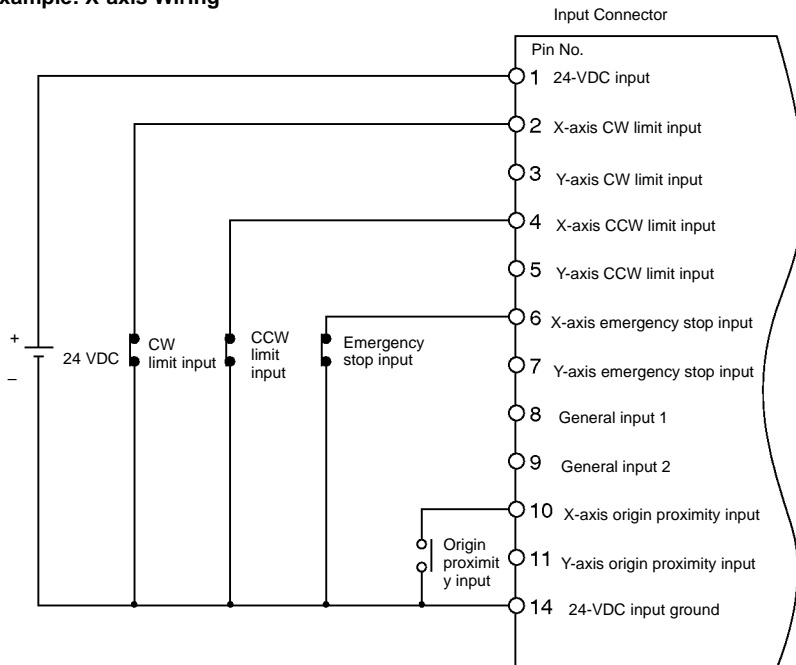

Connector:
Wire and assemble the connector by using the connector case provided with the Unit or by using the XW2Z-100J-F1 MC Unit Terminal Block Connecting Cable.

Using the MC Unit Terminal Block

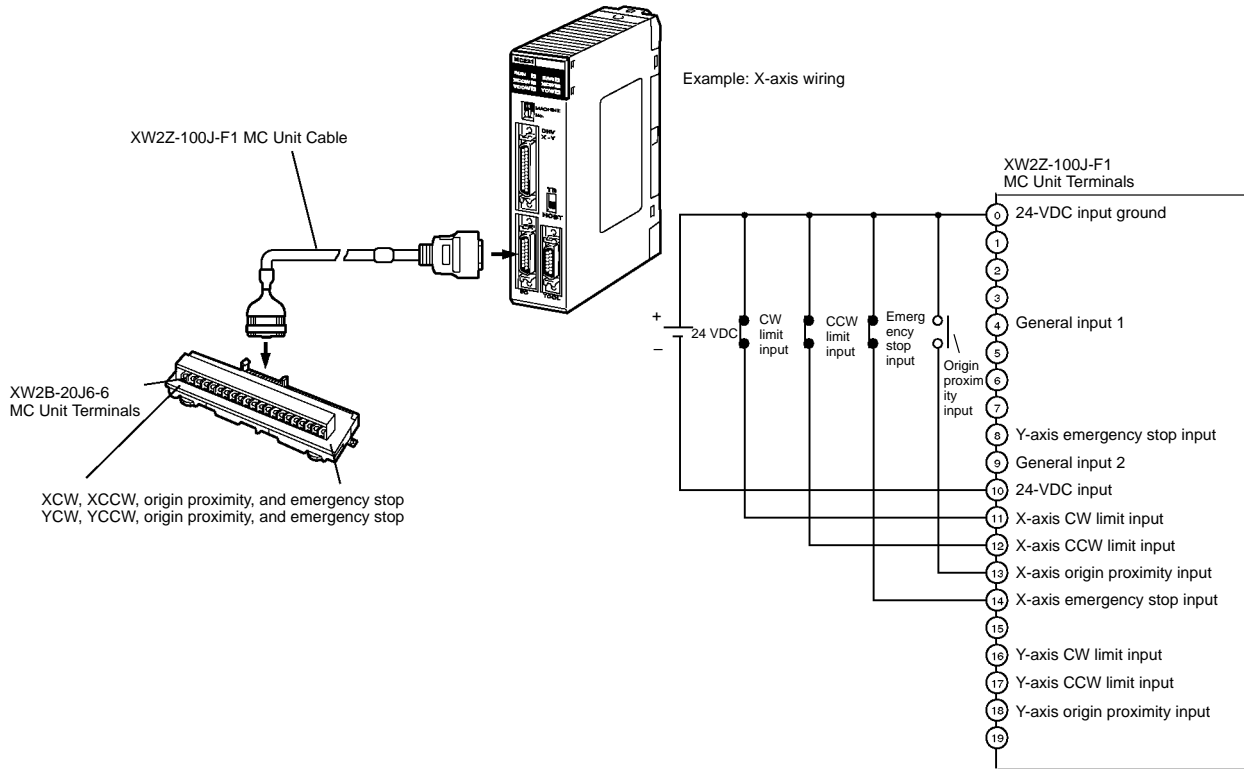

DRV X-Y Connector: Servodriver Connection

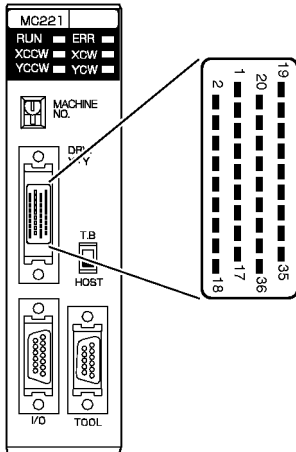

Pin	Symbol	Name	Function
1	+24 V	24 VDC input	External power supply's 24-VDC input (for the X-Y axes)
2	DC GND	24 VDC input ground	External power supply's 24-VDC ground (for the X-Y axes)
3	XALM	X-axis alarm input	Driver alarm input for the X-axis
4	XRUN	X-axis run output	Driver run output for the X-axis
5	XALMRS	X-axis alarm reset output	Reset output for the X-axis's driver alarm.
8	XSGND	X-axis SEN signal ground	SEN signal ground for the X-axis
9	XSOUT	X-axis SEN signal output	SEN signal output for the X-axis (absolute encoder driver)
10	X-GND	X-axis feedback ground	Feedback ground for the X-axis
11	X-A	X-axis phase A input	Phase A feedback input for the X-axis
12	X- \bar{A}	X-axis phase \bar{A} input	Phase \bar{A} feedback input for the X-axis
13	X-B	X-axis phase B input	Phase B feedback input for the X-axis
14	X- \bar{B}	X-axis phase \bar{B} input	Phase \bar{B} feedback input for the X-axis
15	X-Z	X-axis phase Z input	Phase Z feedback input for the X-axis
16	X- \bar{Z}	X-axis phase \bar{Z} input	Phase \bar{Z} feedback input for the X-axis
17	XOUT	X-axis speed control	Speed control voltage to the X-axis driver
18	XAGND	X-axis speed control ground	Ground for the X-axis's speed control voltage
19	+F24V	24 VDC output	24-VDC input to the driver (for the X-Y axes)
20	FDC GND	24 VDC output ground	Ground for 24-VDC outputs (for the X-Y axes)
21	YALM	Y-axis alarm input	Driver alarm input for the Y-axis
22	YRUN	Y-axis run output	Driver run output for the Y-axis
23	YALMRS	Y-axis alarm reset output	Reset output for the Y-axis's driver alarm.
26	YSGND	Y-axis SEN signal ground	SEN signal ground for the Y-axis
27	YSOUT	Y-axis SEN signal output	SEN signal output for the Y-axis (absolute encoder driver)
28	Y-GND	Y-axis feedback ground	Feedback ground for the Y-axis
29	Y-A	Y-axis phase A input	Phase A feedback input for the Y-axis
30	Y- \bar{A}	Y-axis phase \bar{A} input	Phase \bar{A} feedback input for the Y-axis
31	Y-B	Y-axis phase B input	Phase B feedback input for the Y-axis
32	Y- \bar{B}	Y-axis phase \bar{B} input	Phase \bar{B} feedback input for the Y-axis
33	Y-Z	Y-axis phase Z input	Phase Z feedback input for the Y-axis
34	Y- \bar{Z}	Y-axis phase \bar{Z} input	Phase \bar{Z} feedback input for the Y-axis
35	YOUT	Y-axis speed control	Speed control voltage to the Y-axis driver
36	YAGND	Y-axis speed control ground	Ground for the Y-axis's speed control voltage

■ Servodriver Cables (Optional)

When using OMRON's U-, H-, or M-series Servodrivers, use Special Servodriver Cables that are available as options to connect the MC Unit to Servodrivers.

Connector:
When the Special Cables shown on the left are not to be used, wire and assemble the connector by using the connector case provided with the Unit.

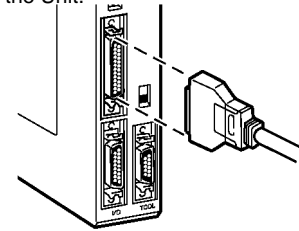

Series		Cable model number		Length (m)
		For two axes	For single axis	
U-series	R88D-U for 30-W to 750-W Servodrivers	R88A-CPU001M2	R88A-CPU001M1	1.0
		R88A-CPU002M2	R88A-CPU002M1	2.0
	R88D-U for 1-W to 5-kW Servodrivers	R88A-CPUB001M2	R88A-CPUB001M1	1.0
		R88A-CPUB002M2	R88A-CPUB002M1	2.0
H-series	R88D-H	R88A-CPH001M2	R88A-CPH001M1	1.0
		R88A-CPH002M2	R88A-CPH002M1	2.0
M-series	R88D-M	R88A-CPM001M2	R88A-CPM001M1	1.0
		R88A-CPM002M2	R88A-CPM002M1	2.0

U-series Servodrivers:

R88A-CPU001M2/002M2 (30 to 750 W)
R88A-CPUB001M2/002M2 (1 to 5 kW)

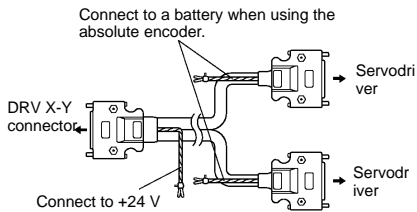

H-series Servodrivers:

R88A-CPH001M2/002M2

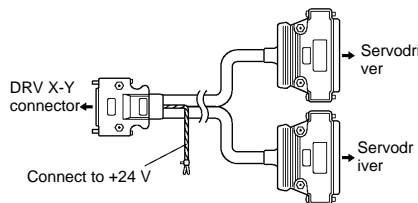

M-series Servodrivers:

R88A-CPM001M2/002M2

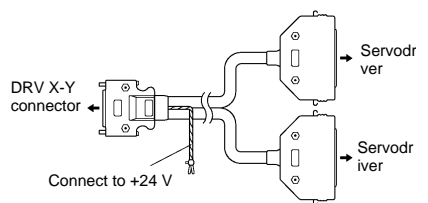

■ Connection Examples

Connection to U-series 30-W to 750-W Models (Using an Absolute Encoder)
 Special Servodriver Cable: R88A-CPU00□M2

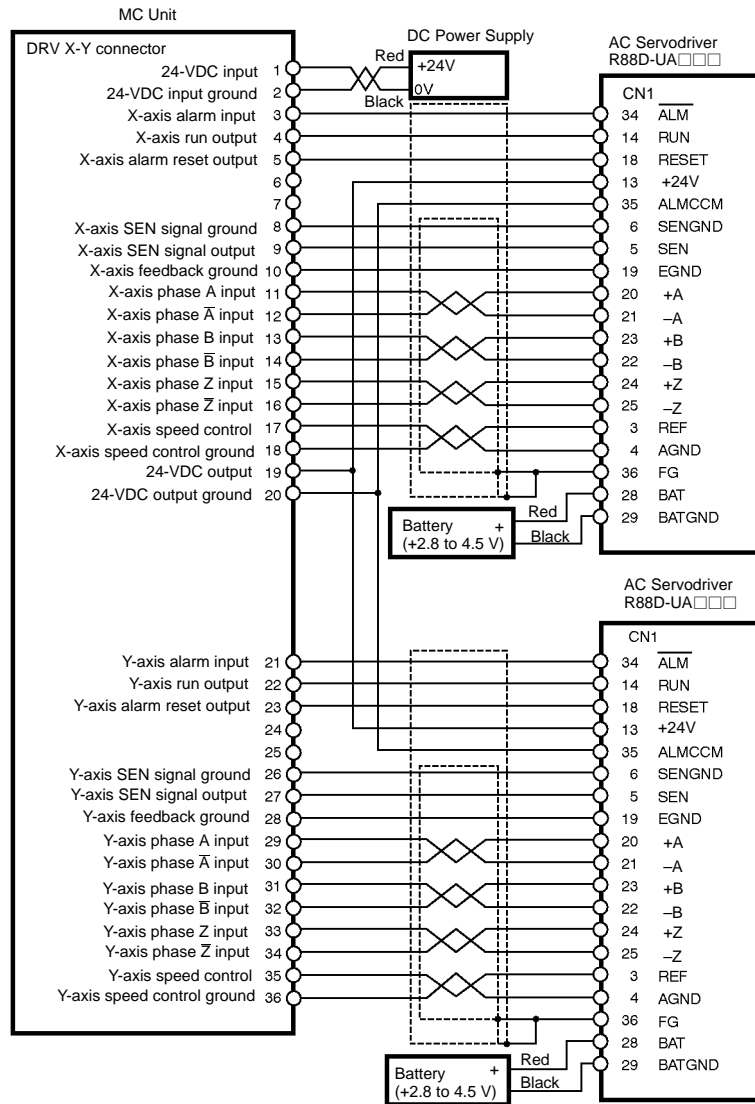

■ Dimensions

Note: All units are in millimeters unless otherwise indicated.

C200H-MC221

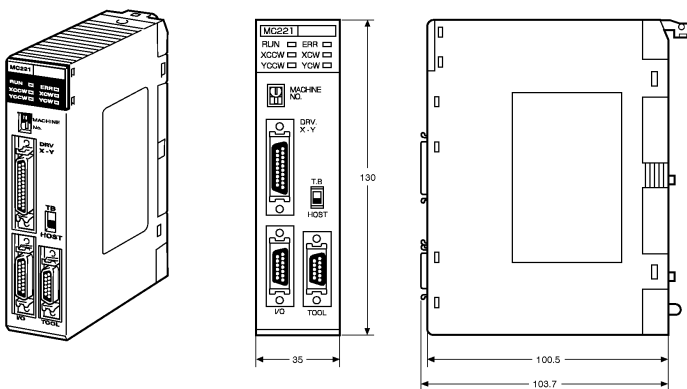

Dimensions with the Unit Mounted

Unit: mm

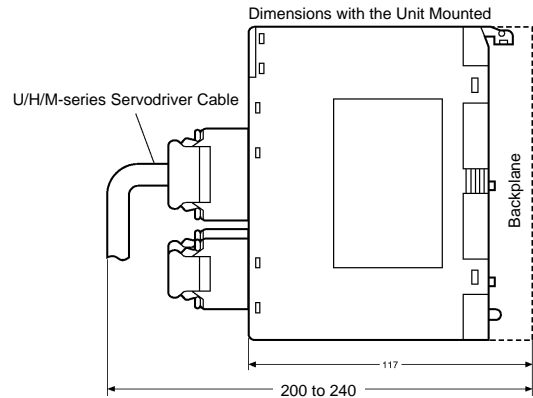

ALL DIMENSIONS SHOWN ARE IN MILLIMETERS.
 To convert millimeters into inches, multiply by 0.03937. To convert grams into ounces, multiply by 0.03527.

OMRON Corporation
Systems Components Division
66 Matsumoto
Mishima-city, Shizuoka 411-8511
Japan
Tel: (81)559-77-9633
Fax: (81)559-77-9097

Regional Headquarters

OMRON EUROPE B.V.
Wegalaan 67-69, NL-2132 JD Hoofddorp
The Netherlands
Tel: (31)2356-81-300/Fax: (31)2356-81-388

OMRON ELECTRONICS, INC.
1 East Commerce Drive, Schaumburg, IL 60173
U.S.A.
Tel: (1)847-843-7900/Fax: (1)847-843-8568

OMRON ASIA PACIFIC PTE. LTD.
83 Clemenceau Avenue,
#11-01, UE Square,
Singapore 239920
Tel: (65)835-3011/Fax: (65)835-2711

Authorized Distributor:

Note: Specifications subject to change without notice.

Cat. No. R061-E1-1

Printed in Japan
0100-0.7M